



Grandstream Networks, Inc.

DP75x Series

DP750 – Administration Guide



DP750 - Administration Guide

WELCOME

Thank you for purchasing Grandstream DP750 DECT IP Base Station and DP720 DECT Handset.

The DP750 is a powerful DECT VoIP base station that pairs with up to 5 of Grandstream’s DP720 DECT handsets to offer mobility to business and residential users. It supports a range of 300 meters outdoors and 50 meters indoors to give users the freedom to move around their work or home space, delivering efficient flexibility. This DECT VoIP base station supports up to 10 SIP accounts and 5 concurrent calls while also offering 3-way voice conferencing, full HD audio and integrated PoE. A shared SIP account on all handsets will add seamless unified features that gives users the ability to answer all calls regardless of location in real-time. The DP750 supports a variety of auto-provisioning methods and TLS/SRTP/ HTTPS encryption security. When paired with Grandstream’s DP720, the DP750 offers a powerful DECT VoIP base station that allows any business or residential user to create a cordless VoIP solution.

The DP720 is a DECT cordless VoIP phone that allows users to mobilize their VoIP network throughout any business, warehouse, retail store and residential environment. It is supported by Grandstream’s DP750 DECT VoIP base station and delivers a combination of mobility and top-notch telephony performance. Up to five DP720 handsets are supported on each DP750 while each DP720 supports a range of up to 300 meters outdoors and 50 meters indoors from the base station. The DP720 touts a suite of top-notch telephony features including support for up to 10 SIP accounts and 2 concurrent calls per handset, full HD audio, a 3.5mm headset jack, multi-language support, a speakerphone and more. When paired with Grandstream’s DP750 DECT Base Station, the DP720 offers a powerful DECT VoIP handset that allows any business or residential user to create a cordless VoIP solution.

PRODUCT OVERVIEW

Feature Highlights

The following tables contain the major features of the DP750 / DP720:

<p>DP750</p> 	<ul style="list-style-type: none">○ 5 handsets.○ 10 accounts.○ 10 Lines.○ 5 Concurrent calls.○ PoE power support.○ 300m range outdoor / 50m range indoor.
---	--

Table 1: DP750 Features at a Glance

<p>DP720</p> 	<ul style="list-style-type: none"> ○ DECT Cordless HD. ○ 1.8 inch (128×160) TFT color LCD. ○ 250 hours standby / 20 hours talk time. ○ 15 languages embedded. ○ 10 accounts. ○ 2 concurrent calls. ○ 5 ring modes.
---	---

Table 2: DP720 Features at a Glance

DP750 Technical Specifications

The following table resumes all the technical specifications including the protocols / standards supported, voice codecs, telephony features, languages and upgrade/provisioning settings for the Base station DP750.

Air Interface	<p>Telephony standards: DECT</p> <p>Frequency bands:</p> <ul style="list-style-type: none"> ○ 1880 – 1900 MHz (Europe), 1920 – 1930 MHz (US) ○ 1910 – 1920 MHz (Brazil), 1786 – 1792 MHz (Korea) ○ 1893 – 1906 MHz (Japan), 1880 – 1895 MHz (Taiwan) <p>Number of channels: 10 (Europe), 5 (US, Brazil or Japan), 3 (Korea), 8 (Taiwan)</p> <p>Range: up to 300 meters outdoor and 50 meters indoor</p>
Peripherals	<p>5 LED indicators: Power, Network, Register, Call, DECT</p> <p>Reset button, Pairing/Paging button</p> <p>One 10/100 Mbps auto-sensing Ethernet port with integrated PoE</p>
Protocols/Standards	<p>SIP RFC3261, TCP/IP/UDP, RTP/RTCP, HTTP/HTTPS, ARP/RARP, ICMP, DNS (A record, SRV, NAPTR), DHCP, PPPoE, SSH, TFTP, NTP, STUN, SIMPLE, LLDP-MED, LDAP, TR-069, 802.1x, TLS, SRTP, IPv6 (pending)</p>
Voice Codecs	<p>G.711μ/a-law, G.723.1, G.729A/B, G.726-32, iLBC, G.722, OPUS, G.722.2/AMR-WB (special order), in-band and out-of-band DTMF (in audio, RFC2833, SIP INFO), VAD, CNG, PLC, AJB</p>
Telephony Features	<p>Hold, transfer, forward, 3-way conference, downloadable phonebook (XML, LDAP, up to 3000 entries), call waiting, call log (up to 300 records), auto answer, flexible dial plan, music on hold, server redundancy and fail-over</p>
Sample Applications	<p>Currency (pending)</p>
QoS	<p>Layer 2 QoS (802.1Q, 802.1p) and Layer 3 QoS (ToS, DiffServ, MPLS)</p>

Security	User and administrator level access control, MD5 and MD5-sess based authentication, 256-bit AES encrypted configuration file, TLS, SRTP, HTTPS, 802.1x media access control, DECT authentication & encryption
Multi-language	English, Czech, German, Spanish, French, Arabic, Hebrew, Italian, Russian, Netherlands, Japanese, Polish, Chinese Simple, Chinese Tradition, Korean, Portuguese, Slovakian, Serbian, Swedish and Turkish.
Upgrade/ Provisioning	Firmware upgrade via FTP/FTPS, HTTP/HTTPS, mass provisioning using TR-069 or AES encrypted XML configuration file
Multiple SIP Accounts	Up to ten (10) distinct SIP accounts per system Each handset may map to any SIP account(s) Each SIP account may map to any handset(s)
Ring Group	Flexible options when multiple handsets share the same SIP account <ul style="list-style-type: none"> ○ Circular Mode: all phones ring sequentially, starting with the phone after the one which rang last. ○ Linear Mode: all phones ring sequentially in the predetermined order, starting with the first phone each time. ○ Parallel Mode: all phones ring concurrently; after one phone answers, the remaining available phones can make new calls
Power & Green Energy Efficiency	Universal Power Supply Input AC 100-240V 50/60Hz; Output 5VDC, 1A; Micro-USB connection; PoE: IEEE802.3af Class 1, 0.44W–3.84W
Package Content	Base unit, Universal Power Supply, Ethernet cable, Quick Installation Guide, GPL Statement
Dimensions	28.5 mm (H) x 130 mm (W) x 90 mm (D)
Weight	Base unit: 143g, Universal Power Supply: 50g; Package: 360g
Temperature and Humidity	Operation: -10° to 55°C (14 to 131°F); Storage: -20° to 60°C (-4 to 140°F); Humidity: 10% to 90% non-condensing
Compliance	FCC: Part 15D, 47 CFR 2.1093, Part 15B CE: EN60950; EN301489-1-6; EN301406 RCM: AS/NZS60950 ANATEL: #2288-16-9452

Table 3: DP750 Technical Specifications

DP720 Technical Specifications

The following table resumes all the technical specifications including the protocols / standards supported, voice codecs, telephony features, languages and upgrade/provisioning settings for the DP720 handset.

Air Interface	<p>Telephony standards: DECT</p> <p>Frequency bands:</p> <ul style="list-style-type: none"> ○ 1880 – 1900 MHz (Europe), 1920 – 1930 MHz (US) ○ 1910 – 1920 MHz (Brazil), 1786 – 1792 MHz (Korea) ○ 1893 – 1906 MHz (Japan), 1880 – 1895 MHz (Taiwan) <p>Number of channels: 10 (Europe), 5 (US, Brazil or Japan), 3 (Korea), 8 (Taiwan)</p> <p>Range: up to 300 meters outdoor and 50 meters indoor</p>
Peripherals	<p>1.8 inch (128×160) color TFT LCD</p> <p>23 keys including 2 softkeys, 5 navigation / menu keys, 4 dedicated function keys for SEND, POWER/END, SPEAKERPHONE, MUTE</p> <p>3-color MWI LED</p> <p>3.5mm headset jack</p> <p>Removable belt clip</p> <p>Micro-USB port for alternative charging and non-battery operation</p>
Protocols/Standards	Hearing Aid Compatibility (HAC) compliant
Voice Codecs	G.722 codec for HD audio and G.726 codec for narrow band audio (G.711μ/a-law, G.723.1, G.729A/B, iLBC and OPUS are supported via companion DECT base station DP750), AEC, AGC, Ambient noise reduction
Telephony Features	Hold, transfer, forward, 3-way conference, call park, call pickup, downloadable phonebook, call waiting, call log, auto answer, click-to-dial, flexible dial plan, music on hold
Sample Applications	Currency (pending)
HD Audio	Yes, in both Handset and Speakerphone modes
Security	DECT authentication & encryption
Multi-language	English, Czech, German, Spanish, French, Hebrew, Italian, Netherlands, Japanese, Chinese, Chinese simple, Polish, Russian, Chinese Simple, Chinese Tradition, Korean, Portuguese, Slovakian, Serbian, Swedish, Turkish and Arabic.
Upgrade/Provisioning	Software Upgrade Over-The-Air (SUOTA), handset provisioning Over-The-Air
Multiple Line Access	Each handset may access up to 10 lines
Power & Green Energy Efficiency	Universal Power Supply Input AC 100-240V 50/60Hz; Output 5VDC 1A; Micro-USB connection; Rechargeable 800mAh Ni-MH Low Self-Discharge (LSD) AAA batteries (250 hours of standby time and 20 hours of talk time)
Package Content	Handset unit, universal power supply, charger cradle, belt clip, 2 batteries, Quick Installation Guide

Dimensions (H x W x D)	Handset: 155 x 50 x 26 mm, charger cradle: 35 x 63.5 x 54 mm
Weight	Handset: 138g, charger cradle: 71g, universal power supply: 50g; Package: 360g
Temperature and Humidity	Operation: -10° to 50°C (14 to 122°F); Charging: 0 to 45°C (32 to 113°F); Storage: -20° to 60°C (-4 to 140°F); Humidity: 10% to 90% non-condensing
Compliance	FCC: Part 15D; 47 CFR 2.1093 & IEEE1528-2013, Part68, Part 15B CE: EN60950; EN301489-1-6; EN301406; EN50360; EN62209-1 RCM: AS/NZS60950; AS/ACIF S004 ANATEL: #2288-16-9452

Table 4: DP720 Technical Specifications

GETTING STARTED

This chapter provides basic installation instructions including the list of the packaging contents and also information for obtaining best performance with the DP720 IP DECT phone and its base station DP750.

Equipment Packaging

DP720	DP750
<ul style="list-style-type: none"> o 1 Handset unit o 1 Universal power supply 5V o 1 Charger cradle o 1 Belt clip o 2 Rechargeable batteries o 1 Quick Installation Guide 	<ul style="list-style-type: none"> o 1 Base unit o 1 Universal power supply 5V o 1 Ethernet cable o 1 Quick Installation Guide o 1 GPL Statement

Table 5: Equipment Packaging

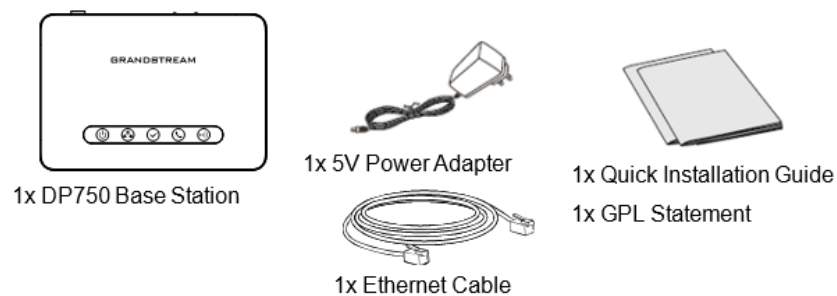

Figure 1: DP750 Package Content

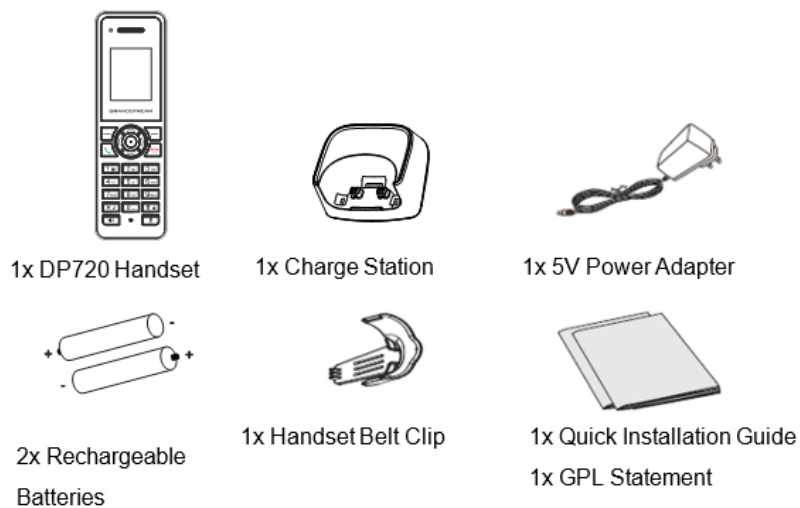

Figure 2: DP720 Package Content

Note

Check the package before installation. If you find anything missing, contact your system administrator.

Connecting DP750

To setup the DP750 Base Station, please follow the steps below:

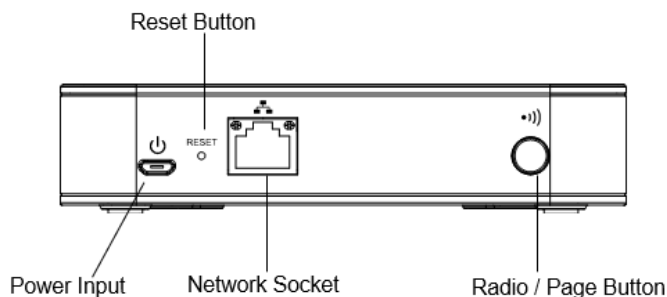

Figure 3: DP750 Back View

You have two options for power and network connection of the base station: AC power or Power over Ethernet (PoE).

Note

For better signal range, we recommend to install DP750 horizontally with LED side facing toward the usage area. For example, if you just put it on a desk, the LED better face up, if you mount it on the ceiling, it better LED face down, in both cases, it toward the space area.

Connecting via AC power

1. Connect the micro-USB connector into the related port on the base station and connect the other end of the power adapter into an electrical power outlet.
2. Connect the supplied Ethernet cable between the Internet port on the base station and the Internet port in your network or the switch/hub device port.

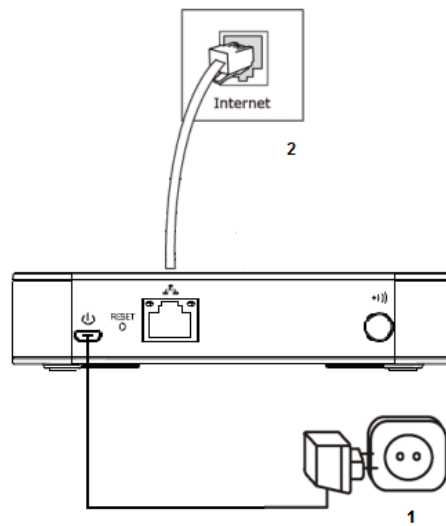

Figure 4: Connecting the Base station

Connecting via PoE

To connect the base station using PoE, you need to connect the Ethernet cable provided (or 3rd party network cable) between the Network Socket on the base station to Ethernet port of your PoE switch/hub.

Setting up DP720 handset

Please follow below steps to insert batteries into the handset:

1. Open the battery compartment cover.
2. Insert the batteries in the correct polarity.
3. Close the battery compartment cover.

Note

Please charge the batteries fully before using the handset for the first time

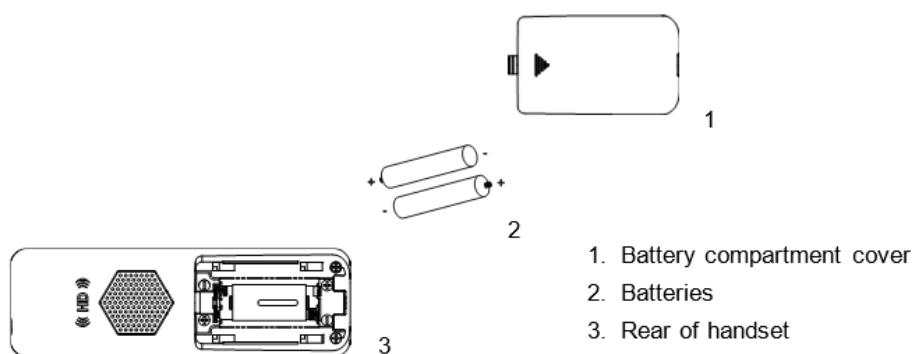

Figure 5: Setting up the DP720

Battery Information

- **Technology:** Nickel Metal Hydride (Ni-MH)
- **Size:** AAA
- **Voltage:** 1.2V
- **Capacity:** 800mAh
- **Charging time:** 12 hours from empty to full
- **Standby time:** up to 250 hours

- **Talk time:** up to 20 hours' active talk time

In order to get the best performance of your DP720 handset, we recommend using original batteries provided in the package or batteries compliant with above specifications.

The specifications may differ depending on the age and capacity of the batteries used.

Important Note

Be careful when inserting the batteries into your handset to avoid any risk of short-circuit, which lead to damage your batteries and/or the handset itself. Do not use damaged batteries which can increase the risk of serious harm.

Setting up the Charge Station

Please refer to the following steps for setting up the charge station and charging the handset:

1. Connect the DC plug on the power adapter to the micro-USB connector on the charge station.
2. Connect the other end of the power adapter into an electrical power outlet.
3. After setting up the handset and the charge station, place the handset in the charge station.

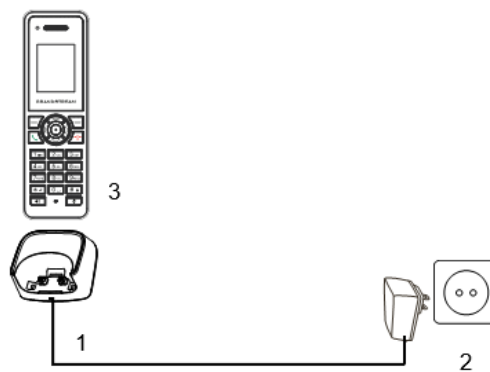





Figure 6: Setting up the charge station

DP750 LED Patterns

The DP750 has 5 LED lights on it. Please refer to the following table for the meaning of each light.



Table 6: DP750 LED Patterns

LED Light	Status
	Indicates Power ON/OFF.
	Indicates access to the network. Remains ON while there is access to the network.
	Indicates if a SIP account is registered.
	Indicates status of the lines. Blinking: A line is in use. Solid ON: All lines are free.



The Radio icon for pairing the DP720 and DP750; when holding the Radio button, blinking indicates a pairing attempt.

DP720 Handset Description

The LCD screen and the Keypad are the main hardware components of the DP720.

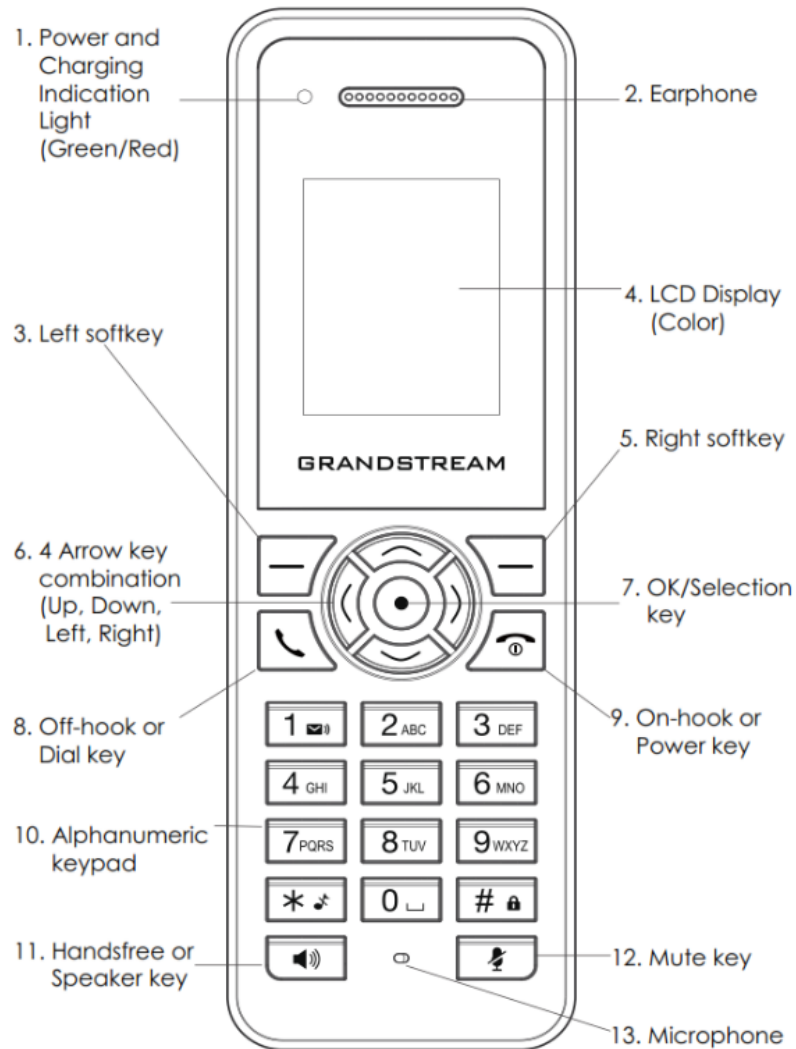

Figure 7: Handset Keys Description









Key	Description
1. Power and Charging Indication Light	Red: Charging. Green: Charge completed. Blinking: Missed call(s) or Voice Mail received.
2. Earphone	Delivers audio output.
3, 5 Left and Right softkeys	Correspond to functions displayed on the LCD. These functions change depending on the current context.
4. LCD Display	Shows call information, handset status icons, prompt messages, etc.
6. 4 Arrow key combination	Allows navigation of the cursor through the displayed menu options.







7.	OK/Selection key	Selects the option chosen by the cursor. (Enters the main menu from the home screen.)
8.	Off-hook / Dial key	Enters dialing mode, or dials number entered.
9.	On-hook / Power key	Terminates calls or turns the handset on / off.
10.	Alphanumeric Keypad	Provides the digits, letters, and special characters in context-sensitive applications. For + sign, press and hold key 0.
11.	Hands-free/Speaker key	Switches between Handset and Hands-free / Speaker modes.
12.	Mute key	Activates or Deactivates the Mute feature.
13.	Microphone	Picks up audio earpiece and hands-free calls.







Table 7: Keypad Keys Description















DP720 Icons Description

The following table contains description of each icon that might be displayed on the LCD screen of the DP720 handset.

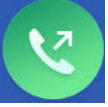
	Battery status Not equipped with battery
	Battery status Battery empty
	Battery status Battery low
	Battery status Battery normal
	Battery status Battery full
	Battery status Charging
	Signal status Not subscribed
	Signal status Not in range

	<p>Signal status</p> <p>Signal very low</p>
	<p>Signal status</p> <p>Signal low</p>
	<p>Signal status</p> <p>Signal normal</p>
	<p>Signal status</p> <p>Signal good</p>
	<p>Signal status</p> <p>Signal very good</p>
	<p>Microphone MUTE Status</p> <p>OFF – Not muted ON – Muted</p>

	<p>Speaker status</p> <p>OFF – Speaker is inactivated ON – Speaker is activated</p>
	<p>Headset icon</p>
	<p>Missed Call icon</p>
	<p>Voicemail icon</p>
	<p>Ringtone status</p> <p>OFF – Ringtone off (Silent mode) ON – Ringtone on</p>
	<p>Keypad Lock status</p> <p>OFF – Keypad unlock ON – Keypad locked</p>

	<p>DND Status.</p> <p>OFF – Do Not Disturb disabled</p> <p>ON – Do Not Disturb enabled</p>
	<p>Call forward</p>
	<p>Call waiting</p>
	<p>Information</p>
	<p>Account not registered</p>
	<p>Account Registered</p>
	<p>Error message</p>
	<p>Handset number</p>
	<p>Incoming Call notification</p>
	<p>Outgoing Call notification</p>
	<p>Missed Call notification</p>
	<p>Voicemail notification</p>
	<p>Contacts</p>
	<p>Call History</p>
	<p>Registration</p>
	<p>Voice Mail</p>





	Preferences
	Shortcut
	Call features
	Status
	Settings

Table 8: DP720 Icons Description

DP720 Handset Menu

The handset has an easy-to-use menu structure. Every menu opens a list of options. To open the main menu, press "Menu" (left softkey) when the handset is on and in standby mode. Press Arrow keys to navigate to the menu option you require. Then press "Select" (left softkey) or **OK/Selection key** to access further options or confirm the setting displayed. To go to the previous menu item, press "Back" (right softkey). You can press **Power** key at any time to cancel and return to standby mode. If you do not press any key, the handset automatically reverts to standby mode after 20 seconds.

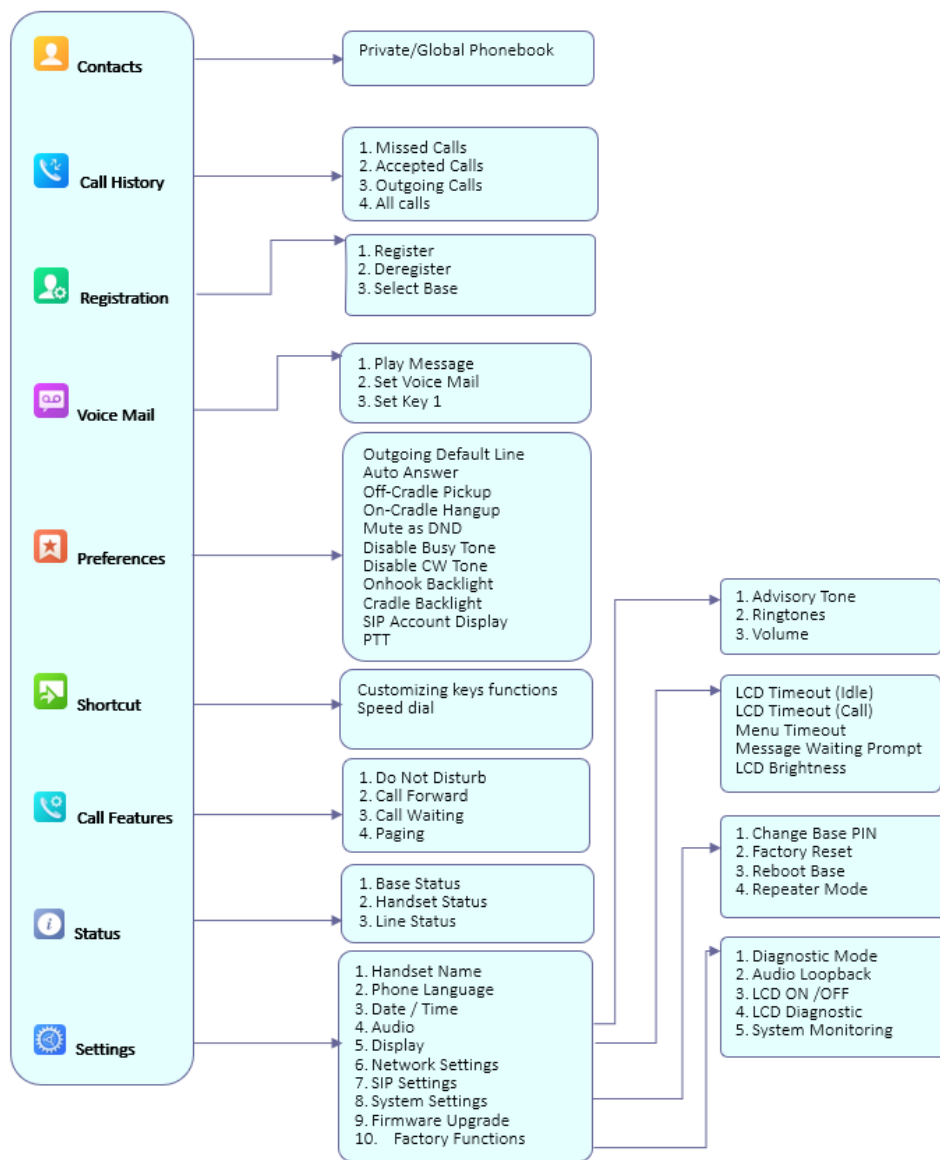

Figure 8: DP720 Menu Structure

<p>Conta cts</p>	<p>Display the contacts created on the handset DP720 and/or the ones imported via XML or LDAP on DP750.</p>
<p>Call Histor y</p>	<p>Display the call history:</p> <ol style="list-style-type: none"> 1. Missed Calls. 2. Accepted Calls. 3. Outgoing Calls. 4. All Calls. <p>Note: You can add contacts to Shared Contacts directly from call logs.</p>
<p>Regist ration</p>	<ul style="list-style-type: none"> o Register <p>Register your handset to base station.</p> <ul style="list-style-type: none"> o Deregister <p>Deregister your handset from base station.</p> <ul style="list-style-type: none"> o Select Base <p>Select base station.</p>

Voice Mail	<p>1. Play Message</p> <p>Play voice mail messages received.</p> <p>1. Set Voice Mail</p> <p>Configure voice mail parameters.</p> <p>1. Set Key 1</p> <p>Configure Key 1 as VM speed dial for selected account.</p>
-------------------	--

- **Outgoing Default Line**

Select account to be use by default for outgoing calls.

- **Auto Answer**

Enable/Disable Auto Answer. (Default is Disabled).

- **Off-Cradle Pickup**

Enable/Disable Off-Cradle Pickup. If enabled, users can answer the calls by picking up the handset off-cradle. (Default is Disabled).

- **On-Cradle Hangup**

Enable/Disable On-Cradle Hangup. If enabled, users can end the call by placing the handset on-cradle. (Default is Disabled).

- **Mute as DND**

Enable/Disable Mute as DND. If enabled, pressing mute key on idle state will set the phone to DND mode. (Default is Enabled)

- **Disable Busy Tone**

Enable/Disable Busy Tone. If set to enabled, busy tone will not be played. (Default is Disabled).

Preferences

- **Disable CW Tone**

Enable/Disable CW Tone. If set to enabled, Call Waiting Tone will not be played. (Default is Disabled).

- **Onhook Backlight**

Enable/Disable Onhook Backlight. If enabled, pressing  key on idle screen will switch off LCD screen. (Default is Disabled)

- **Cradle Backlight**

Enable/Disable/Dim Cradle Backlight. If enabled, LCD will remain backlit when the handset is placed on-cradle/charging. If set to "Dim", LCD brightness will be reduced when the handset is placed on-cradle/charging. (Default is Disabled)

- **SIP Account Display**

Select which SIP Account information will be displayed on the screen.

- **Name Only:** Display SIP Account Name only. (Default)

- **ID Only:** Display SIP User ID only.

- **None:** No account information will be displayed.

- **PTT**

Enable/Disable Push To Talk. If set to enabled, pressing PTT soft key, a PTT call will be initiated. (Default is Disabled)

<p>Short cut</p>	<ul style="list-style-type: none"> ○ Customizing keys functions <p>L : Configure Left Softkey function in idle. Function can be set as Menu, History, Contacts, Line or PTT. Default is Menu.</p> <p>: Configure Right Softkey function. Function can be set as History, Contacts, Line or PTT Default is Contacts.</p> <p>R</p> <ul style="list-style-type: none"> ◀: Configure Arrow UP Key function. Default is Outgoing Calls (Call History). ◀: Configure Arrow DOWN key function. Default is Accepted Calls (Call History). ◀: Configure Arrow LEFT key function. Default is Ringer Volume Down. ◀: Configure Arrow RIGHT key function. Default is Ringer Volume Up. <p>Select key and press OK button to configure function. Following functions are available for arrow keys: 1. Disabled, 2. Missed Calls, 3: Accepted Calls, 4: Outgoing Calls, 5: History, 6: Contacts, 7: Status, 8: Line, 9: Voice Mail, 10: Ringer Volume Up, 11: Ringer Volume Down, 12: Audio Volume Up, 13: Audio Volume Down, 14: Intercom.</p> <ul style="list-style-type: none"> ○ Speed Dial <p>Assign contact numbers as speed dial.</p> <p>Select a key [2], [3], [4], [5], [6], [7], [8] or [9] and press OK button. Select "Edit" to manually specify the destination number, or select "From Contacts" to select a contact as speed dial destination.</p>
<p>Call Features</p>	<p>1. Do Not Disturb</p> <p>Enable/disable do not disturb mode on the phone.</p> <p>1. Call Forward</p> <p>Configure call forward feature.</p> <p>1. Call Waiting</p> <p>Configure call waiting feature.</p> <p>1. Paging</p> <p>Configures Inter-Handsets paging feature.</p> <p>Note: Paging between handsets doesn't require registered sip account.</p>
<p>Status</p>	<p>1. Base Status</p> <p>Display Base status (Firmware, IP address, Subnet mask, Gateway, MAC Address)</p> <p>1. Handset Status</p> <p>Display Handsets status (Model RF, Firmware, IPEI)</p> <p>1. Line Status</p> <p>Display Line status (Account name, Status)</p>

Settings

1. Handset Name

Change the Handset name.

1. Phone Language

Select the language to be displayed on the phone's LCD. (Default is English.)

1. Date/Time

Configure date and time on the Handsets.

1. Audio

Specify ringtones for internal/external calls, the volume, advisory tones (Keypad, Confirmation, Low battery notifications).

1. Display

Configure backlight, LCD timeout (Idle/Call), LCD brightness, Message Waiting Prompt and menu key timeout.

1. Network Settings

Configure IP addresses and select DHCP/Static IP mode.

1. SIP Settings

Configure/View SIP accounts settings.

1. System Settings

Change Base PIN code, perform factory reset, reboot base and configure repeater mode.

1. Firmware Upgrade

Upgrade the firmware version of the Handsets.

1. Factory Functions

- *Keypad Diagnostic*

All LEDs will light up, and the LCD will display a table listing the names of all keys in red. Press any key to diagnose; the key's name will display in blue. After all keys are diagnosed, a prompt message ("PASS") will display; press "Back" (right softkey) to exit.

Note: User can long press arrow UP key to exit at any time.

- *Audio Loopback*

Speak to the phone using speaker/Handsets/headset. If you can hear your voice, your audio is working fine. Press "Exit" softkey to exit audio loopback mode.

- *LCD ON / OFF*

Select this option to turn off LCD. Press any button to turn on LCD.

- *LCD Diagnostic*

Select this option to enter LCD Diagnostic mode. Press "Next" (left softkey) to display white screen. Continue pressing the left softkey to view all remaining screens (black, blue, red, and green) and then exit. End the test early by pressing the right softkey.

- *LED Diagnostic*

Enters this option and press "1" to start LED Diagnostic (you will notice that the color of the LED will be changing). Press "2" to quit.

- *System Monitoring*

Displays RSSI, battery voltage and RPN information.

CONFIGURATION GUIDE





The DP750 can be configured using:

- Web GUI embedded on the DP750 using PC's web browser.
- LCD Configuration Menu using the paired DP720 keypad.

Via Web GUI you can configure all the functions supported by the DP750; while via paired DP720, you can access limited configuration and need the base station PIN code for some options.

Obtain DP750 Base Station IP Address via paired DP720

DP750 is by default configured to obtain IP address from DHCP server where the unit is located. In order to know which IP address is assigned to your DP750, please follow below steps using a paired DP720 handset with your DP750 base station. Please see [Register DP720 Handset to DP750 Base Station](#) .

1. Press "Menu" (left softkey)  or **OK** button  on DP720 to view operation menu.
2. Press Arrow (Up, Down, Left, Right) keys to move the cursor to **Status** icon  , then press "Select" (left softkey)  or **OK** button  , then select **Base Status**.
3. Using Arrow keys, navigate down to view the IP address of the DP750.

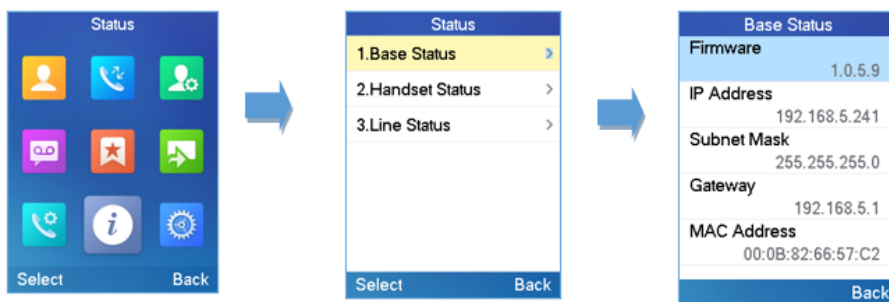

Configuration via Web Browser

The DP750 embedded Web server responds to HTTP/HTTPS GET/POST requests. Embedded HTML pages allow a user to configure the DP750 through a Web browser such as Google Chrome, Mozilla Firefox and Microsoft's IE.

Accessing the Web UI

1. Connect the computer to the same network as DP750.
2. Make sure the DP750 is booted up.
3. You may check DP750 IP address via a subscribed DP720 on its LCD menu at: **Status** → **IP Address**. Please see [Obtain DP750 Base station IP Address via paired DP720](#)
4. Open Web browser on your computer.
5. Enter the DP750's IP address in the address bar of the browser.

6. Enter the administrator's username and password to access the Web Configuration Menu. (Starting HW version 1.7A the default admin username is 'admin' while the admin password is the random password that can be found on the sticker at the back of the unit. For lower hardware versions; the default username and password are: admin/admin).

Note

The computer must be connected to the same sub-network as the DP750. This can be easily done by connecting the computer to the same hub or switch as the DP750.

Web GUI Languages

Currently the DP750 series web GUI supports English, Czech, German, Spanish, French, Arabic, Hebrew, Italian, Russian, Netherlands, Japanese, Polish, Chinese Simple, Chinese Tradition, Korean, Portuguese, Slovakian, Serbian, Swedish and Turkish

Users can select the displayed language in web GUI login page, or at the upper right of the web GUI after logging in

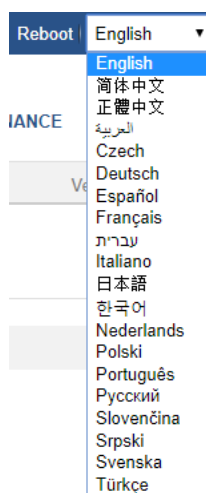

Figure 9: DP750 Web GUI Language



Icons Bar Shortcut

Users can find the icon bar right below the main menu of every page as displayed on following screenshot:



Figure 10: Icons Bar Shortcut

Please refer to following table describing the use of each icon:

Icon	Description
	Refresh Button: Allows users to refresh the current page.
	Subscribe Button: Allows users to open the subscription.
	Paging Button: Allows users to page all the registered DP720 handsets.

Saving the Configuration Changes

After users makes changes to the configuration, pressing the **Save** button will save but not apply the changes until the **Apply** button on the top of web GUI page is pressed. Users can instead directly press the **Save and Apply** button. We recommend rebooting or powering cycle the phone after applying all the changes.

Web UI Access Level Management

There are two default passwords for the login page:

User Level	User name	Password	Web Pages Allowed
End User Level	user	123	Only Status, Settings and Maintenance
Administrator Level	admin	The random password that can be found on the sticker at the back of the unit Starting from hardware version 1.7A. For lower hardware versions, the admin password is 'admin'	All pages

The password is case sensitive with maximum length of 25 characters.

Note

When accessing the web GUI with normal user level, "Advanced Settings" page will be hidden.

When changing any settings, always SUBMIT them by pressing the **Save** or **Save and Apply** button on the bottom of the page. If using the **Save** button, after making all the changes, click on the **Apply** button on top of the page to submit. After submitting the changes in all the Web GUI pages, reboot DP750 to have the changes take effect if necessary; most of the options under the **Settings** page require reboot, but options under the **Accounts** and **Phonebook** pages do not.

Changing User Level Password

1. Access the Web GUI of your DP750 using the admin's username and password. (Starting HW version 1.7A the default admin username is 'admin' while the admin password is the random password that can be found on the sticker at the

back of the unit. For lower hardware versions; the default username and password are: admin/admin).

2. Press **Login** to access your settings.
3. Go to **Maintenance** → **Web/SSH Access**.
4. In **Web/SSH Access** page, locate **User Password** section:
 1. Type in your new user password in **New Password** field.
 2. Type in again same entered password in **Confirm Password** field.
5. Press **Save and Apply** to save your new setting.

The screenshot shows the 'Web/SSH Access' configuration page. On the left is a navigation menu with 'Web/SSH Access' highlighted in red. The main content area has three sections: 'User Password', 'Admin Password', and 'Access Control Lists'. The 'User Password' section is highlighted with a red box and contains two input fields: 'New Password' and 'Confirm Password'. The 'Admin Password' section also has 'New Password' and 'Confirm Password' fields. The 'Access Control Lists' section has two text areas: 'White list for WAN side' and 'Black list for WAN side'.

Figure 12: User Level Password

Important Note

DO NOT USE same password for both user and admin accounts.

Changing Admin Level Password

1. Access the Web GUI of your DP750 using the admin's username and password. (Starting HW version 1.7A the default admin username is 'admin' while the admin password is the random password that can be found on the sticker at the back of the unit. For lower hardware versions; the default username and password are: admin/admin).
2. Press Login to access your settings.
3. Go to Maintenance → Web/SSH Access.
4. In **Web/SSH Access** page, locate **Admin Password** section:
 - Type in your new Admin Password in **New Password** field.
 - Type in again same entered password in **Confirm Password** field.
5. Press **Save and Apply** to save your new setting.

Figure 13: Admin Level Password

Important Note

Note: DO NOT USE same password for both user and admin accounts.

Changing HTTP / HTTPS Web Access Port

1. Access the Web GUI of your DP750 using the admin's username and password (Starting HW version 1.7A the default admin username is 'admin' while the admin password is the random password that can be found on the sticker at the back of the unit. For lower hardware versions; the default username and password are: admin/admin).
2. Press Login to access your settings.
3. Go to Maintenance → Security Settings → Web/SSH.
4. In Web/SSH Settings page, locate HTTP / HTTPS Web Port field and change it to your desired/new HTTP / HTTPS port.
Note: By default, the HTTP port is 80 and HTTPS is 443.
5. Select the Web Access Mode depending on desired protocol (HTTP or HTTPS).
6. Press **Save and Apply** to save your new setting.

Note







A reboot is required for this change to take effect.

Web Configuration Definitions

This section describes the options in the DP750 Web UI. As mentioned, you can log in as an administrator or an end user.

- **Status:** Display system info, network status, base and repeater status, account status, and line options.
- **Profiles:** Configure the profiles with general settings, network settings, SIP settings, audio settings, call settings and ring tones.
- **DECT:** Configure DECT general settings, account settings and handset line settings.
- **Settings:** Configure ring tones and system features.
- **Maintenance:** Configure networks, upgrading and provisioning, web/SSH access, TR-069, security settings, date and time, and syslog.
- **Phonebook:** Manage phonebooks: global/shared (XML or LDAP) and private (XML).

Status Page Definitions

Account Status	
Account	Displays list of configured accounts' names, from Account 1 to Account 10.
SIP User ID	Displays list of SIP user id registered.
SIP Server	Displays list of SIP Server.
SIP Registration	Shows the status of SIP registration. If the SIP account is successfully registered, it will display "YES" with green background. If the SIP account is not registered, it will display "NO" with red background.
HS Mode	Displays the HS mode configured for each account.
HS status table	<p>Illustrates both handsets and SIP accounts statuses. Each column is dedicated to one HS; each row shows the status of the account on that HS:</p> <ul style="list-style-type: none">   Gray: HS is not configured to use this account.  Green: HS is idle on this account.  Green Blinking: HS is using this account. Red: HS is not available.  Red/Orange Blinking: HS is ringing on this account.  Brown: The line is configured, but the handset is not subscribed. <p>For example, if accounts 1, 3 and 4 are assigned to HS3 with account 3 in use, the column for HS3 will have cell 3 with red icon, cells 1 and 4 with green icon, and cells 2 and 5 with gray icon.</p>
DECT Base Status	
Base Station Name	Displays name of base station. Default is DP750_[last 6 digit of MAC address] .

Base DECT FW Version	Shows firmware version of base DECT.
Base DECT RF Region	Indicates region of base DECT RF.
Base DECT RFPI Address	Specifies DECT RFPI (Radio Fixed Part Identity) address which is a unique identity for the base.
Global Functions	<ul style="list-style-type: none"> – Unsubscribe Handsets: Unsubscribes all handsets from DECT base station. – Upgrade Handsets: Upgrade all handsets from DECT base station.
Handset Status	<ul style="list-style-type: none"> • Handset Name: Displays index and name (customizable) of each handset. • IPEI: Indicates IPEI number of each handset; this is the unique identity for the handset. If the handset is in range, the IPEI will be displayed with a green background, otherwise, it will be displayed with a red background. • Battery icon = : Illustrates battery status for each Handset; it can be either: <ul style="list-style-type: none"> ▫ Fully charged ▫ Not fully charged ▫ Low, needs to be charged or replaced ▫ Charging • Page: Sends paging request to corresponding handset, which will receive incoming ring tone and “Paging” will be displayed on their LCD screens; this function helps you locate the handsets. • Unsubscribe: Unsubscribes corresponding handset from DECT base station. • HS Firmware: Indicates handset’s firmware version number. <ul style="list-style-type: none"> ○ Upgrade: Shows handset upgrade status or trigger handset upgrade process. ○ RAM Dump: Notifies when a debug file is available after recovery. ○ Note: The DECT page status keeps refreshing automatically and periodically to update the information about the registered handsets.
DECT Repeater Status	

Paired Devices	<p>Displays paired repeaters showing:</p> <ul style="list-style-type: none"> ○ Model: Displays model of repeater. ○ Name: Displays the name of the repeater. ○ IP address: Displays the DECT repeater IP address. ○ MAC address: Displays the DECT repeater MAC address. ○ Status: Displays the status of DECT Repeater: <ul style="list-style-type: none"> ○ Online when the repeater is turned on and ready for use. ○ Offline when the repeater is turned off. ○ Signal Strength: Display link status and signal strength, different status is available (excellent, good, weak and poor) depending on the distance between the repeater and base station. ○ Active Calls: Displays number of active calls. ○ Unlink: Click on Unlink button to disconnect the DECT Repeater from the base station.
Discovered Devices	<p>Displays discovered repeaters using:</p> <ul style="list-style-type: none"> ○ Model: Displays model of repeater. ○ Name: Displays the name of the repeater. ○ IP address: Displays the DECT repeater IP address. ○ MAC address: Displays the DECT repeater MAC address. ○ Link: Clicks Link button to connect DECT Repeater to the base station.
Line Options	
Account	Displays list of configured accounts' names, from Account 1 to Account 10.
SIP User ID	Displays list of SIP user id registered.
DND	Shows DND (Do Not Disturb) feature status (per SIP account).
Forward	Indicates destination to which all incoming calls will be forwarded (per SIP account).
Busy Forward	Indicates destination to which incoming calls will be forwarded when the line is busy (per SIP account).
Delayed Forward	Indicates destination to which incoming calls will be forwarded if the call is not answered within a specified period of time or number of rings (per SIP account).
Network Status	
MAC Address	Shows Device ID in hexadecimal format. This is needed by network administrators for troubleshooting. The MAC address will be used for provisioning and can be found on the label on original box and on the label located on the bottom panel of the device.
IP Address Mode	Indicates used IP address mode: DHCP, Static IP or PPPoE.
IP Address	Displays assigned IP address. Example: 192.168.5.110

Subnet Mask	Displays assigned subnet mask. Example: 255.255.255.0
Gateway	Displays assigned default gateway. Example: 192.168.5.1
PPPoE Link Up	Indicates PPPoE connection status.
DNS Server 1	Shows assigned DNS server address 1. Example: 8.8.8.8
DNS Server 2	Shows assigned DNS server address 2. Example: 8.8.4.4
NAT Traversal	Indicates type of NAT for each Profile. (Based on STUN protocol.)
System Info	
Product Model	Displays product model info. Default is DP750 .
Part Number	Shows product part number. Example: 9610003814A (last 2 digits show HW version, in this example 14A for HW version 1.4A)
Hardware Version	Shows the hardware version of the phone.
Software Version	<ul style="list-style-type: none"> ○ Firmware Status: Displays the status of the firmware loaded. ○ Boot: Specifies Boot version. ○ Core: Specifies Core version. ○ Base: Specifies Base version. ○ Prog: Specifies Prog version. This is the main firmware release number, which is always used for identifying the software system of the DP750. ○ Locale: Specifies Locale version. ○ Recovery: Specifies Recovery version. ○ Handset: Specifies Handset firmware version.
System Up Time	Indicates system uptime since last reboot.
System Time	Shows actual time and date according to your configuration.
Service Status	Reveals status of VoIP applications.

Table 9: Status Page Definitions

Profiles Page Definitions

General Settings

Profile Active	Activates or deactivates SIP profile.
Profile Name	Determines the name of the profile, this profile name can also be used in Handsets config provisioning for validation. By default, the values are profile 1 – profile 4.
SIP Server	Configures SIP server IP address or domain name provided by VoIP service provider. This is the primary SIP server used to send/receive SIP messages from/to DP752.
Failover SIP Server	Specifies failover SIP server IP address or domain name provided by VoIP service provider. This server will be used if the primary SIP server becomes unavailable.
Prefer Primary SIP Server	Prefers primary SIP server. The profile will register to primary Server if registration with Failover server expires. Default is No.
Outbound Proxy	Specifies IP address or domain name of outbound proxy, media gateway or session border controller. Used by DP752 for firewall or NAT penetration in different network environments. If symmetric NAT is detected, STUN will not work, and only outbound proxy can correct the problem.
Backup Outbound Proxy	IP address or Domain name of the Secondary Outbound Proxy which will be used when the primary proxy cannot be connected.
Voice Mail Access Number	Defines the voice mail portal access number to allow users accessing their voice messages. Max allow length 30
Network Settings	
Layer 3 QoS Settings	
SIP Diff-Serv	Defines SIP Diff-Serv value. Default is 24.
RTP Diff-Serv	Defines RTP Diff-Serv value. Default is 46.
DNS Settings	
DNS Mode	Selects DNS mode to use for the client to look up server. Default is A Record. A Record: resolves IP Address of target according to domain name. SRV: DNS SRV resource records indicate how to find services for various protocols. NAPTR/SRV: Naming Authority Pointer according to RFC 2915. Use Configured IP: If selected, please fill in Primary IP, Backup IP 1 and Backup IP 2 to be used for server look up.
DNS SRV Failover mode	This feature is used to configure the preferred IP mode for DNS SRV. If selected “default”, first IP from query result will be applied; If selected “Saved one until DNS TTL”, previous IP will be applied before reaches DNS timeout; If selected “Saved one until no response”, previous IP will be applied even after DNS time out until it cannot response.
Register before DNS SRV failover	When the DNS SRV Failover Mode is enabled, you can also choose to “Register before DNS SRV failover” that can waive the 3 failed tries, or still try 3 times then use the failover DNS.
Maximum Number of SIP Request Retries	Defines the number of SIP retries before DNS failover. the Default value is 2.
Failback Expiration (m)	Defines the expiration time in minutes when using Broadsoft R23 failback mode. Default value is 60.
Primary IP	Specifies primary IP address where the base sends DNS query to, when “Use Configured IP” is

	selected for DNS mode.
Backup IP 1	Specifies backup IP 1 address where the base sends DNS query to, when “Primary IP” is not responding.
Backup IP 2	Specifies backup IP 2 address where the base sends DNS query to, when “Backup IP 1” is not responding.
NAT Settings	
NAT Traversal	<p>Enables/disables NAT traversal mechanism. If activated (by choosing “STUN”) and a STUN server is also specified (Maintenance → Network Settings → STUN Settings); the base performs according to STUN client specification.</p> <p>Under this mode, embedded STUN client will detect if and what type of firewall/NAT is being used. If detected NAT is a Full Cone, Restricted Cone, or a Port-Restricted Cone, the base will use its mapped public IP address and port in all of its SIP and SDP messages. If NAT Traversal field is set to “Keep Alive”, the base will periodically (every 20 seconds) send a blank UDP packet (with no payload data) to SIP proxy to keep the “ping hole” on the NAT open.</p>
Use NAT IP	Defines NAT IP address used in SIP/SDP messages. It should only be used if required by ITSP.
Proxy-Require	Determines a SIP Extension to notify the SIP server that the base is behind a NAT/Firewall.
Use SBC	Indicate whether or not a SBC server is used, if users want to work under SBC associated with 3CX, they should enable this feature to have better communication with the server.
SIP Settings	
Basic Settings	
SIP Transport	Selects transport protocol for SIP packets; UDP or TCP or TLS. Make sure your SIP server or network environment supports SIP over the selected transport method. Default is UDP.
SIP URI Scheme When Using TLS	Specifies if “sip” or “sips” will be used when TLS/TCP is selected for SIP Transport. The default setting is “sips”.
Use Actual Ephemeral Port in Contact TCP/TLS	<p>Defines whether the actual ephemeral port in contact with TCP/TLS will be used when TLS/TCP is selected for SIP Transport. If set to No, these port numbers will use the permanent listening port on the phone. Otherwise, they will use the ephemeral port for the connection.</p> <p>The default setting is “No”.</p>
SIP Registration	Controls whether to send SIP REGISTER messages to the proxy server. Device may not be able to make/receives calls if disabled. Default is Yes.
Unregister on Reboot	Controls whether to clear SIP user’s information by sending an un-register request to the proxy server. The un-registration is performed by sending a REGISTER message with the “Contact” header set to * and Expires=0 parameters to the SIP server. This will unregister all SIP accounts under concerned Profile. The default value is "No".
Add Auth Header on Initial REGISTER	Adds “Authentication” header with blank “nonce” attribute in the initial SIP REGISTER request. Default is No.
Outgoing Calls Without Registration	<p>Enables the ability to place outgoing calls even when not registered (if allowed by ITSP); the device will not be able to receive incoming calls. Any HS member of a hunting group that is not registered with a SIP account, will be able to place outbound calls using the SIP credentials of the primary hunting group HS.</p> <p>For example, HS 1, 3, and 5 are the same Hunting Group members. HS 1 is registered with a SIP</p>

	account. HS 3 and 5 are not reported. HS 3 and 5 will be able to place outbound calls using the SIP account of HS 1, even if Outgoing Call without Registration is set to No. The default is Yes.
Register Expiration	Refreshes registration periodically with specified SIP proxy (in minutes). Maximum interval is 65535 minutes (about 45 days). Default is 60 minutes (or 1 hour).
SIP Registration Failure Retry Wait Time	Sends re-register request after specific time (in seconds) when registration process fails. Maximum interval is 3600 seconds (1 hour). Default is 20 seconds.
SIP Registration Failure Retry Wait Time upon 403 Forbidden	Sends re-register request after specific time (in seconds) when registration process fails due to “403 Forbidden”. Valid range is 0 to 3600 in second. 0 second means stop retry registration. Default is 1200 seconds.
Reregister Before Expiration	Sends re-register request after specific time (in seconds) to renew registration before the previous registration session expires.
Local SIP Port	Defines local port to use by the base for listening and transmitting SIP packets. Default value for Profile 1 is 5060, 6060 for Profile 2, 7060 for Profile 3 and 8060 for Profile 4.
Use Random SIP Port	Controls whether to use configured or random SIP ports. This is usually necessary when multiple base stations are behind the same NAT. Default is No.
Local RTP Port	Defines local RTP port used to listen and transmit RTP packets. Default is 5004.
Use Random RTP Port	Defines local port to use by the base for listening and transmitting RTP packets. Default value for Profile 1 is 5004, 6004 for Profile 2, 7004 for Profile 3 and 8004 for Profile 4.
SIP T1 Timeout	Defines T1 timeout value. It is an estimate of the round-trip time between the client and server transactions. For example, the base station will attempt to send a request to a SIP server. The time it takes between sending out the request to the point of getting a response is the SIP T1 timer. If no response is received the timeout is increased to (2*T1) and then (4*T1). Request re-transmit retries would continue until a maximum amount of time defined by T2. Default is 0.5 seconds.
SIP T2 Timeout	Identifies maximum retransmission interval for non-INVITE requests and INVITE responses. Retransmitting and doubling of T1 continues until it reaches T2 value. Default is 4 seconds.
SIP Timer D	Configures SIP timer D defined in RFC3261. Range of values 0-64. Default is 0.
SIP Timer F	Configures SIP timer F defined in RFC3261. Range of values 0-64. The default is 0.
SIP Timer B	Configures SIP timer B defined in RFC3261. Range of values 0-64. Default is 0.
Enable OPTIONS Keep Alive	Enables OPTIONS Keep Alive, to check SIP server. Default is No.
OPTIONS Keep Alive Interval	Time interval for OPTIONS Keep Alive feature in seconds. Range of values is 1–64800. Default is 30.
OPTIONS Keep Alive Max Lost	A maximum number of lost packets for the OPTIONS Keep Alive feature before the phone sends a re-registration. Range of values 3-10. The default is 3.
Remove OBP from Route	Removes outbound proxy information from “Route” header when sending SIP packets. Default is No.
Support SIP Instance ID	Adds “SIP Instance ID” attribute to “Contact” header in REGISTER request as defined in IETF SIP outbound draft. Default is Yes.

Hold Target Before Refer	Sends re-INVITE to hold transfer target before sending REFER message to transferee. Default is No.
Refer-To Use Target Contact	Includes target's "Contact" header information in "Refer-To" header when using attended transfer. Default is No.
SUBSCRIBE for MWI	Sends periodic "SUBSCRIBE" requests (depends on "Register Expiration" parameter) for message waiting indication service. Default is No.
Enable 100rel	Appends "100rel" attribute to the "required" header of the initial signaling messages. Default is No.
TEL URI	Indicates E.164 number in the "From" header by adding "User=Phone" parameter or using "Tel:" in SIP packets, if the base has an assigned PSTN Number. Disabled: Will use "SIP User ID" information in the Request-Line and "From" header. Disabled: Will use "SIP User ID" information in the Request-Line and "From" header. Enabled: "Tel:" will be used instead of "sip:" in the SIP request. Please consult your carrier before changing this parameter. The default is Disabled.
Do Not Escape '#' as %23 in SIP URI	Replaces "#" by "%23" when sending SIP packets. Default is No.
Disable Multiple m Line in SDP	Sends only one m line in SDP, regardless of how many m fields are in the incoming SDP. Default is No.
Use Privacy Header	Controls whether the Privacy Header will be present in SIP INVITE message. Default is Default.
Use P-Preferred-Identity Header	Controls whether PPI Header will be present in SIP INVITE message. Default is Default.
Ignore Alert-Info Header	This option is used to configure default ringtone. If set to "Yes", configured default ringtone will be played. The default setting is No.
Caller ID Display	When set to "Auto", the phone will look for the caller ID in the order of P-Asserted Identity Header, Remote-Party-ID Header and From Header in the incoming SIP INVITE. When set to "Disabled", all incoming calls are displayed with "Unavailable". When set to "From Header", the phone will display the caller ID based on the From Header in the incoming SIP INVITE. The default setting is "Auto".
Allow SIP Reset	Allows to reset the devices directly through SIP Notify. If "Allow SIP Reset" is set to "YES", then the base receives the NOTIFY from the SIP server with Event: reset, the base should perform a factory reset after the authentication. The authentication in this case can be either with: The admin password if no SIP account is configured on the base. With the credentials of the SIP account if configured on the base. By default, it is set to "No".
Session Timer	
Enable Session Timer	Enables/Disables the Session Timer Support. Default is Yes.
Session Expiration	Enables periodic refresh of SIP session via a SIP request (UPDATE, or re-INVITE). When the session interval expires and there is no refresh via an UPDATE or re-INVITE message, the session will be terminated. Session Expiration is the time at which the session is considered timed out, if no successful session refresh transaction occurs beforehand. Default is 180 seconds.
Min-SE	Defines Minimum session expiration (in seconds). Default is 90 seconds.

Caller Request Timer	Uses session timer when making outbound calls if remote party supports it. Default is No.
Callee Request Timer	Uses session timer when receiving inbound calls with session timer request. Default is No.
Force Timer	It uses a session timer even if the remote party does not support this feature. Selecting “No” will enable session timer only when the remote party supports it. The default is No. To turn off Session Timer, select “No” for Caller Request Timer, Callee Request Timer, and Force Timer.
UAC Specify Refresher	Specifies which end will act as refresher for outgoing calls: UAC: The base station acts as the refresher. UAS: Callee or proxy server act as the refresher. Default is Omit.
UAS Specify Refresher	Specifies which end will act as a refresher for incoming calls: UAS: The base station serves as the refresher. UAC: Callee or proxy server act as the refresher. The default is Omit.
Force INVITE	Uses INVITE message to refresh the session timer. Default is No.
Security Settings	
Validate Incoming Messages	Defines whether incoming messages will be validated or not. Default is No.
Check SIP User ID for Incoming INVITE	Checks SIP User ID in the Request URI of incoming INVITE; if it doesn't match the base SIP User ID, the call will be rejected. Direct IP calling will also be disabled. Default is No.
Accept Incoming SIP from Proxy Only	Checks SIP address of the Request URI in the incoming SIP message; if it doesn't match SIP server address of the account, the call will be rejected. Default is No.
Authenticate Incoming INVITE	Challenges the incoming INVITE for authentication with SIP 401 Unauthorized message. Default is No.
Authenticate Server Certificate Domain	Checks server TLS certificate to ensure that common name matches the configured SIP server. Default is No.
Authenticate Server Certificate Chain	Checks server TLS certificate to ensure that it is authorized by a known certificate authority. Default is No.
Trusted CA Certificate	Treats entered certificate as a valid CA for authenticating the server TLS certificate. The default is No.
Audio Settings	
DTMF Settings	
Send DTMF	Specifies the mechanism to transmit DTMF digits. Default is via RTP (RFC2833) In audio: which means DTMF is combined in the audio signal (not very reliable with low-bit-rate codecs); Via RTP (RFC2833): permits to specify DTMF with RTP packet. Users could know the packet is DTMF in the RTP header as well as the type of DTMF. SIP INFO: uses SIP INFO to carry DTMF. The defect of this mode is that it's easily to cause desynchronized of DTMF and media packet for the reason the SIP and RTP are transmitted respectively.

Disable DTMF Negotiation	Uses above DTMF order without negotiation. Default is No.
DTMF Payload Type	Defines payload type for DTMF using RFC2833.
Vocoder Settings	
Preferred Vocoder	Configures vocoders in a preference list (up to 8 preferred vocoders) that will be included with same order in SDP message. Vocoder types are G.711 A-/U-law, G.722, G.726-32, G.723, G.729, iLBC and OPUS
Voice Frames per TX	Transmits a specific number of voice frames per packet. Default is 2; increases to 10/20/32/64 for G711/G726/G723/other codecs respectively.
G723 Rate	Operates at specified encoding rate for G.723 vocoder. Available encoding rates are 6.3kbps or 5.3kbps. Default is 6.3kbps.
G726-32 Packing Mode	Defines G726-32 packing mode ("ITU" or "IETF"). Default is ITU.
iLBC Frame Size	Specifies iLBC packet frame size (20ms or 30ms). Default is 20ms.
iLBC Payload type	Determines payload type for iLBC. The valid range is between 96 and 127. Default is 97.
Disable OPUS stereo in SDP	Disables OPUS stereo attribute in SDP header. Default is No.
OPUS Payload Type	Determines OPUS payload type. The valid range is between 96 and 127. Default is 123.
Use First Matching Vocoder in 200OK SDP	Includes only the first matching vocoder in its 200OK response, otherwise it will include all matching vocoders in same order received in INVITE. Default is No.
Callee Codec Negotiation Priority	When callee, whose codecs are given priority in Codecs negotiation, local or remote. Set it Remote will use remote codec priority, or local will use local priority. Default is Remote.
SRTP Mode	<p>Selects the SRTP mode to use ("Disabled", "Enabled but not forced", "Enabled and forced", "Follow SIP Transport", or "Optional").</p> <ol style="list-style-type: none"> Disabled: SRTP is not used at all. Voice communication will be transmitted without encryption or authentication, which may pose a security risk. Enabled and forced: Ensures that SRTP is always used for voice communication. The base station enforces the use of SRTP and requires connected devices to support it. If a device doesn't support SRTP, the call may be rejected or the communication won't be established. Follow SIP Transport: When "Follow SIP Transport" is chosen, the SRTP protocol follows the transport protocol specified in the SIP signaling messages to determine when to start and stop the encryption and decryption of the RTP traffic. Optional: This option allows SRTP to be used, but it is not mandatory. The base station can negotiate with the devices to determine whether to enable SRTP. If SRTP is agreed on, the communication will be encrypted and authenticated. If not, the communication will proceed without SRTP. <p>The default is Disabled.</p>
Crypto Life Time	Adds crypto life time header to SRTP packets. Default is Yes.
Silence Suppression (VAD)	Allows detecting the absence of audio and conserves bandwidth by preventing the transmission of "silent packets" over the network. Default is No.
Jitter Buffer Type	Selects jitter buffer type (Fixed or Adaptive) based on network conditions.

Jitter Buffer Length	High (initial 200ms, min 40ms, max 600ms) Note: not all vocoders can meet the high requirement. Medium (initial 100ms, min 20ms, max 200ms).
Voice Monitoring	
Enable RTCP	Enables RTCP statistics and control information. Default settings is RTCP.
Call Settings	
Early Dial	Sends an early INVITE each time a key is pressed when a user dials a number. Otherwise, only one INVITE is sent after full number is dialed (the user presses Dial Key or after “no key entry timeout” expires). This option should be used only if there is a SIP proxy configured and supporting “484 Incomplete Address” responses. Otherwise, the call will likely be rejected by the proxy (with a 404 Not Found error). The default is No. This feature is NOT designed to work with and should NOT be enabled for direct IP-to-IP calling.
Dial Plan Prefix	Adds specified prefix to dialed number.
Dial Plan	<p>Dial Plan Rules: Accept Digits : +,1,2,3,4,5,6,7,8,9,0, *, #, A,a,B,b,C,c,D,d ; Grammar: x – any digit from 0-9;xx+ – at least 2-digit number; xx – exactly 2-digit number; ^ – exclude; . – wildcard, matches one or more characters [3-5] – any digit of 3, 4, or 5; [147] – any digit 1, 4, or 7; <2=011> – replace digit 2 with 011 when dialing <=1> – add a leading 1 to all numbers dialed, vice versa will remove a 1 from the number dialed – or Example 1: {[369]11 1617xxxxxxx} – Allow 311, 611, 911, and any 10-digit numbers of leading digits 1617 Example 2: {^1900x+ <=1617>xxxxxxx} – Block any number with leading digits 1900 and add prefix 1617 for any dialed 7-digit numbers Example 3: {1xxx[2-9]xxxxxx <2=011>x+} – Allow any length of number with leading digit 2 and 10 digit-numbers of leading digit 1 and leading exchange number between 2 and 9; If leading digit is 2, replace leading digit 2 with 011 before dialing. Default: Outgoing – {x+} Example of a simple dial plan used in a Home/Office in the US: { ^1900x. <=1617>[2-9]xxxxxx 1[2-9]xx[2-9]xxxxxx 011[2-9]x. [3469]11 +x+ } Explanation of example rule (reading from left to right): ^1900x. – prevents dialing any number started with 1900 <=1617>[2-9]xxxxxx – allows dialing to local area code (617) numbers by dialing 7 numbers and 1617 area code will be added automatically 1[2-9]xx[2-9]xxxxxx – allows dialing to any US/Canada Number with 11 digits length 011[2-9]x. – allows international calls starting with 011 [3469]11 – allow dialing special and emergency numbers 311, 411, 611 and 911 +x+ – allow dialing any digit with leading + sign; example: +16175669300 Note: In some cases, user wishes to dial strings such as *123 to activate voice mail or other application provided by service provider. In this case * should be predefined inside dial plan feature. An example dial plan will be: { *x+ } which allows the user to dial * followed by any length of numbers. Dial Plan Bypass: Users can bypass the dial plan when making a call from call history by enabling the Feature using Pvalues: Profile 1: P2382=6 Profile 2: P2482=6 Profile 3: P2582=6 Profile 4: P2682=6</p>
Bypass Dial plan	Enable/Disable the dial plan check while making outgoing calls.

	The default setting is “No”.
Use # as Dial Key	Treats “#” as the “Send” (or “Dial”) key. If set to “No”, this “#” key can be included as part of the dialed number. Default is Yes.
Use # as Redial Key	If set to “Yes”, the “#” key will immediately redial the number of the last outgoing call, if no digits have been dialed. The default is Yes.
On Hold Reminder Tone	Supports to disable or enable “On Hold Reminder Tone” to play a reminder tone when a call is on hold.
Match Incoming Caller ID	<p>Specifies matching rules with number, pattern or Alert Info text. When the incoming caller ID or Alert Info matches the rule, the phone will ring with selected distinctive ringtone.</p> <p>Matching rules:</p> <ul style="list-style-type: none"> • Specific caller ID number. For example, 8321123; • A defined pattern with certain length using x and + to specify, where x could be any digit from 0 to 9. Samples: xx+ : at least 2-digit number; xx : only 2-digit number; [345]xx: 3-digit number with the leading digit of 3, 4 or 5; [6-9]xx: 3-digit number with the leading digit from 6 to 9. • Alert-Info text <p>Users could configure the matching rule as certain text (e.g., priority) and select the custom ring tone mapped to it. The custom ring tone will be used if the phone receives SIP INVITE with Alert-Info header in the following format: Alert-Info: <http://127.0.0.1>; info=priority Selects the distinctive ringtone for the matching rule. When the incoming caller ID or Alert Info matches the rule, the phone will ring with the selected ring.</p> <p>Note: Alert info can also be input as a string.</p>
Allow Auto Answer by Call-info/Alert-Info	If set to “Yes”, the phone will automatically turn on the speaker phone to answer incoming calls, based on the SIP Call-Info/Alert-Info header sent from the server/proxy. The default setting is “No”
Custom Alert-Info for Auto Answer	Used exclusively to match the contents of the info parameter in the Alert-Info header for auto answer. The default auto answer headers will not be matched if this is defined.
Allow Barging for Auto Answer by Call-Info/Alert-Info.	Allows to auto answer a call by Call-Info/Alert-Info, even the phone is current in middle of a call, it is disabled by default.
Enable Call Features	Enables do not disturb, call forward and other call features via the local feature codes on the base. Otherwise, ITSP feature codes can be used. Default is Yes.
Disable Call Waiting Caller ID	Disables displaying caller ID when receiving a second incoming call. Default is No.
Enable Call Waiting in Parallel Mode	Enables call waiting for accounts using this profile which are set to Parallel ring mode. Default is No.
Disable Visual MWI	Disables use of visual message waiting indicator when there is an unread voicemail message. Default is No.
Transfer on Conference Hangup	Transfers the call to the other party if the conference initiator hangs up. Default is No.
Ring Timeout	Stops ringing when incoming call is not answered within a specific period of time. Default is 60 seconds.
Hunting Group Ring Timeout	Forwards incoming call to the next member of a hunt group if not answered within a specific

	period of time. Default is 20 seconds.
Send Anonymous	Sets “From”, “Privacy” and “P_Asserted_Identity” headers in outgoing INVITE message to “anonymous”, blocking caller ID. Default is No.
Anonymous Call Rejection	Rejects incoming calls with anonymous caller ID with “486 Busy here” message. Default is No.
Special Feature	Selects Soft switch vendors’ special mode. Example of vendors: Broadsoft, CBCOM, RNK, Huawei, ZTE IME, Phone Power, Metaswitch, Bitrix24, Telstra, and Kandy. Default is Standard.
Music On Hold URI	Configure the music on hold URI to call when a call is on hold if server support it.
Allow Unsolicited REFER	Allow unsolicited REFER to accomplish an outgoing call.
Feature Key Synchronization	When enabled, call features like DND, call forward, call waiting will be synchronized between the server and the phone. It will use NOTIFY to send the status in XML content to server and accept the NOTIFY from the server. This feature following the Broadsoft and MetaSwitch standard. Any server following the same standard will be compatible with this feature.
Call Log	Configure the level of call logs or disable the call log.

Table 10: Profiles Page Definitions

DECT Page Definitions

General Settings	
Base Station Name	Displays the name of the base station. Default is DP75x[last 6 digits of MAC address].
Admin PIN Code	Configures admin PIN code for authentication. Default is 0000
Enable Repeater Mode	Enables the base station repeater mode to associate with available repeaters. Once enabled the base station starts searching for nearby repeaters and open subscription to associate with the available repeaters. This option requires rebooting the base station to take effect. Default is No.
Enable Repeater Management	Enables base station network management of discovered and paired repeaters. Once enabled, users need first to reboot the base station to take effect, then login on the web UI and browser to Status page, a new tab “DECT Repeater Status” will be available to display discovered and paired devices and also allowing users to associate / dissociate repeaters and also access their web GUI. Default is No.
DECT PTT Silence Timer	Sets timeout for PTT call (in minutes) if no handset unmutes. If set to 0, this timer will be disabled.
Clear Call Logs	Deletes call history logs of all handsets from base station
Handset Settings	<p>Handset: Displays list of handsets’ indexes, from HS 1 to HS 5.</p> <p>Handset Name: Allows to customize handset name. Default is “HS1” to “HS5”.</p> <p>Handset Phonebook: Assigns private phonebook to handset. Each handset has a private phonebook or can be disabled. A private phonebook can be shared between specific handsets. Example: PB1 assigned to HS1 and HS2</p> <p>Off-hook Auto-dial: Configures a number to auto dial when off-hook.</p> <p>Off-hook Auto-dial Delay: Configures a delay time for off-hook auto-dial. After configured, when device off-hook playing dial tone, after the configured time of seconds, the device will auto dial to the configured</p>

	number.
SIP Account Settings	
Account	Displays list of accounts' indexes, from account 1 to account 10.
SIP User ID	Enters SIP user ID provided by VoIP service provider (ITSP). Usually in the form of digit similar to phone number or actually a phone number.
Authenticate ID	Enters account authenticate ID provided by VoIP service provider (ITSP). Can be identical to or different from "SIP user ID".
Password	Specifies account password provided by VoIP provider (ITSP) to register to SIP servers
Name	Chooses a name to be associated to user. Supported length is 256.
Profile	Selects the profile ID (1/2/3/4).
HS Mode	<p>Determines HS modes; the base station supports 4 hunting group modes and 1 non-hunting group:</p> <ul style="list-style-type: none"> ● Circular mode: all phones ring sequentially, starting with the phone after the one which rang last. ● Linear mode: all phones ring sequentially in the predetermined order, starting with the first phone each time. ● Parallel mode: all phones ring concurrently; after one phone answers, the remaining available phones can make new calls. ● Non-Hunting Group: an account will be assigned to a single specific handset.
Active	Activates/deactivates the account.
Handset Line Settings	
Handset Line Settings	<p>Configures handset line settings; the base station supports up to 10 SIP accounts, 5 handsets; each Handset can be configured with up to 10 accounts.</p> <p>Please be aware that the handset line settings will be affected by DID settings (hunting group settings) in "DECT → SIP Account Settings". For more details about Hunting Group, please refer to [Hunting Groups].</p>
Handset Settings (1-5)	
Enable Auto Answer	Enables / disables auto answer of incoming calls to handset. Default setting is No.
Enable Mute for Auto Answer	Enables/disables auto mute right after the call been answer, this can be configured by either the handset GUI or Web UI.
Enable Off hook on Cradle Pickup	Enables / disables off hook of handset when picked up from cradle. Default setting is No.
Enable on hook on Cradle Reposition	Enables / disables on hook of handset when repositioned on cradle. Default setting is No.
Disable Conference	Enables / disables the conference option on this handset. Default setting is No.
Disable Transfer	Enables / disables transfer option on this handset. Default setting is No.
Disable Busy Tone on Remote Disconnect	Enables / disables the busy tone heard in the handset when call is disconnected remotely.

Disable Call Waiting Tone	Disables playing call waiting tone during active call when receiving a second incoming call. The CWCID will still be displayed. Default is No.
Play warning tone for Auto Answer Intercom	Allows to play a warning tone for auto answer for protect the privacy. This setting can be configured by either the handset GUI or the Web UI.
No Key Entry Timeout	Initiates the call within this time interval if no additional key entry during dialing stage. Default is 4 seconds.
Blind transfer wait timeout	Defines the timeout (in seconds) for no key entry during a blind transfer. Default is 30 seconds.
Custom Ringtone	Assigns custom ringtone to specific handset from the ringtones available on the base station. It takes up to 10 ringtone files which have be named as ring1.bin to ring10.bin, and you can assign one ringtone to each handset. Default is Disabled.
Time Format	Set the displayed Time Format on handsets to 12 hours or 24 hours. Default is 12hr.
Date Format	Set the displayed Date Format on handsets.

Table 11: DECT Page Definitions

Settings Page Definitions

Network Settings – Basic Settings			
IP Address Mode	Selects IP address mode (DHCP, Static IP or PPPoE) for DP750 Base Station.		
Preferred DNS Server	Specifies preferred DNS server to use when DHCP, PPPoE or Static mode is set.		
DHCP Settings	<table border="1"> <tr> <td>Host name (Option 12)</td> <td>Specifies the name of the client. The name may or may not be qualified with the local domain name. This field is optional but may be required by ISP.</td> </tr> </table>	Host name (Option 12)	Specifies the name of the client. The name may or may not be qualified with the local domain name. This field is optional but may be required by ISP.
Host name (Option 12)	Specifies the name of the client. The name may or may not be qualified with the local domain name. This field is optional but may be required by ISP.		
Vendor Class ID (Option 60)	Exchanges vendor class ID by clients and servers to convey particular configuration or other identification information about a client. Default is DP7XX .		
PPPoE Settings	Configures PPPoE account ID, password and service name.		
Static IP Settings	Sets IP address, subnet mask, gateway, DNS server 1, and DNS server 2.		

Network Settings – Advanced Settings		
802.1X Mode	Enables/Disables 802.1X mode. To enable this mode, you should select EAP-MD5. Default is Disable .	
802.1X Identity	Configures the identity for 802.1X mode.	
MD5 Password	Determines the MD5 password for 802.1X mode.	
802.1X CA Certificate	Uploads / deletes the 802.1X CA certificates.	
802.1X Client Certificate	Uploads / Deletes the 802.1X Client Certificates.	
Enable LLDP	Activates LLDP (Link Layer Discovery Protocol). Default is No .	
Layer 2 QoS Settings	Enable VLAN	Enables / Disables the VLAN mode. Default is Disabled .
Layer 2 QoS 802.1Q/VLAN Tag	Sets layer 2 QoS 802.1Q/VLAN tag. Default is 0.	
Layer 2 QoS 802.1p Priority Value for SIP signaling	Sets layer 2 QoS 802.1p priority value for SIP signaling. Default is 0 .	
Layer 2 QoS 802.1p Priority Value for RTP media	Sets layer 2 QoS 802.1p priority value for RTP media. Default is 0 .	
STUN Settings	Use STUN	Enables STUN. Default is No .
STUN server	Configures IP address or domain name of STUN server. Only non-symmetric NAT routers work with STUN.	

Number of STUN Response Misses Allowed	Specifies number of STUN response misses allowed before restarting DHCP service. The minimum is 3 misses.	
Keep-Alive Interval	Sends periodically a blank UDP packet to SIP server to keep “ping hole” on the NAT router open. Default is 20 seconds.	
UPnP Discovery Settings	Enable UPnP discovery	Enables/disables UPnP discovery feature. Default is Yes . After enabled, if you have a PC in the same network of DP750, you can browse it directly in your Network. Double click the device will open its web GUI in your default browser.
UPnP discovery notify interval	Specifies in seconds the interval to send out SSDP notifies. Default settings is 30 .	
Management Interface Settings		
Enable Management Interface	Allows administrator to setup a Virtual Network Interface on top of the physical interface for device management. Default is No .	
Management Access	Chooses whether to access using “ Management Interface Only ” (Default) Or “ Both Service and Management Interfaces ”	
Layer 2 QoS 802.1Q/VLAN Tag	Assigns the VLAN Tag of the Layer 2 QoS packets. Default is 0 .	
Layer 2 QoS 802.1p Priority Value	Assigns the priority value of the Layer 2 QoS packets. Valid range is 0 – 7 .	
IP Address Mode	Set the IP mode to either “DHCP” or “Static”. Default is DHCP .	
Static IP Settings		

IP Address	Enter the IP address when static IP is used. Default is 192.168.100.100
Subnet Mask	Enter the Subnet Mask when static IP is used. Default is 255.255.255.0
Gateway	Enter the Default Gateway when static IP is used. Default is 192.168.100.1
DNS Server 1	Enter DNS Server 1 when static IP is used.
DNS Server 2	Enter DNS Server 2 when static IP is used.
Network → Open VPN® Settings	
OpenVPN® Enable	Enables/Disables the OpenVPN® feature. Default settings is No .
OpenVPN® Server Address	Configures the address of the OpenVPN® server.
OpenVPN® Port	Defines the port of the OpenVPN® server. Default is 1194 .
OpenVPN® Transport	Determines network protocol UDP or TCP used for OpenVPN®. Default is UDP .
OpenVPN® CA	Uploads the OpenVPN® CA.
OpenVPN® Certificate	Uploads the OpenVPN® Certificate.
OpenVPN® Client Key	Uploads the OpenVPN® Client Key.
OpenVPN® Cipher Method	Must be the same cipher method used by the OpenVPN® server
OpenVPN® Username	OpenVPN® authentication username (optional)
OpenVPN® Password	OpenVPN® authentication password (optional)

OpenVPN® Comp-Izo	Enables/Disables OpenVPN® Comp-Izo. The setting is enabled by default.
Additional Options	Additional options to be appended to the OpenVPN® config file, separated by semicolon. For example: comp-izo no;auth SHA256 Note: Please use with caution. Make sure that the options are recognizable by OpenVPN® and do not unnecessarily override the other configurations above.
SNMP Settings	
Enable SNMP	Enables/Disables the SNMP feature. Default settings is No
Version	Version SNMP version.
Port	SNMP port. Default is 161 .
Trap Community	Configures the Name of SNMP trap community.
SNMP Trap Version	SNMP Trap Version. Default is Trap Version 3 .
SNMP Trap IP	IP address of the SNMP trap receiver.
SNMP Trap Port	Port of the SNMP trap receiver. Default is 162 .
SNMP Trap Interval	The interval between each trap sent to the trap receiver. Default is 60 .
SNMP Username	Username for SNMP.
Security Level	<ul style="list-style-type: none"> ○ noAuthUser: Users with security level noAuthnoPriv and context name as noAuth. ○ authUser: Users with security level authNoPriv and context name as auth. ○ privUser: Users with security level authPriv and context name as priv. <p>Default is NoAuthUser.</p>
Authentication Protocol	Select the Authentication Protocol: "None" or "MD5" or "SHA". Default is None .
Privacy Protocol	Select the Privacy Protocol: "None" or "DES" or "AES". Default is None .

Authentication Key	Enter the Authentication Key
Privacy Key	Enter the Privacy Key.
SNMP Trap Username	User name for SNMP Trap.
Trap Security Level	<ul style="list-style-type: none"> ○ noAuthUser: Users with security level noAuthnoPriv and context name as noAuth. ○ authUser: Users with security level authNoPriv and context name as auth. ○ privUser: Users with security level authPriv and context name as priv. <p>Default is NoAuthUser.</p>
Trap Authentication Protocol	Select the Authentication Protocol: "None" or "MD5" or "SHA". Default is None .
Trap Privacy Protocol	Select the Privacy Protocol: "None" or "DES" or "AES". Default is None .
Trap Authentication Key	Enter the Trap Authentication Key.
Trap Privacy Key	Enter the Trap Privacy Key
External Service	
Order	Displays the order of the service. (1 – 10)
Service Type	<p>Specifies the service's type. Two options are available: None or GDS.</p> <p>Default setting is None. Note: The DP750 supports up to 10 GDS items.</p> <p>For more details, refer to Facility Access Systems</p>
Account	Specifies the account on which the service will be applied.
System Identification	Specifies the name to identify the service.
System Number	Specifies the system number, in case the service type option is set to GDS, the system number is the SIP user ID configured on GDS37xx, or the IP address of the GDS37xx itself if it's using IP call.

Access Password	Determines the access password, in case the service type option is set to GDS, the access password is the one configured on "Remote PIN to Open the Door" field on GDS37xx settings.
Ring Tones	
System Ring Cadence	<p>Sets ring cadences for all incoming calls.</p> <p>Syntax: c=on1/off1-on2/off2-on3/off3;</p> <p>on1 is the period of ringing ("On time" in "ms") while off1 is the period of silence.</p> <p>Default is set to c=2000/4000; (US standards).Up to three cadences are supported.</p>
Call Progress Tones	<p>Configures tone frequencies according to user preference. By default, the tones are set to North American frequencies. Frequencies should be configured with known values to avoid uncomfortable high pitch sounds. ON is the period of ringing ("On time" in "ms") while OFF is the period of silence. In order to set a continuous ring, OFF should be zero. Otherwise it will ring ON ms and a pause of OFF ms and then repeats the pattern.</p> <ul style="list-style-type: none"> • "Dial tone" • "Ring back tone" • "Busy tone" • "Call-Waiting tone" <p>Please refer to the document below to determine your local call progress tones:</p> <p>http://www.itu.int/ITU-T/inr/forms/files/tones-0203.pdf</p>
System Features	
Disable Direct IP Call	Deactivates Direct IP-to-IP calling function. Default is No .
User-Agent Prefix	This option allows to configure a customized User-Agent Prefix.

Table 12: Settings Page Definitions

Maintenance Page Definitions

Firmware Upgrade	
Firmware Upgrade and Provisioning	Selects how firmware upgrade request will be sent: "Always Check for New Firmware", "Check New Firmware only when F/W pre/suffix changes", or "Always Skip the Firmware Check".

HTTP/HTTPS User Name	Enters user name to authenticate with HTTP/HTTPS server.
HTTP/HTTPS Password	Enters password to authenticate with HTTP/HTTPS server.
Always send HTTP Basic Authentication Information	Includes configured user name and password in HTTP request before receiving authentication challenge from the server. Default is No.
Verify host when using HTTPS	Verifies host name in server certificate when using HTTPS. Default is Yes.
Upgrade via	Selects firmware upgrade method: FTP/FTPS or HTTP/HTTPS.
Firmware Server Path	Sets IP address or domain name of firmware server. The URL of the server that hosts the firmware release. Default is fm.grandstream.com/gs. Note: Make sure to not prepend address with "http://" or any other protocol
Firmware File Prefix	Checks if firmware file is with matching prefix before downloading it. This field enables user to store different versions of firmware files in one directory on the firmware server.
Firmware File Postfix	Checks if firmware file is with matching postfix before downloading it. This field enables user to store different versions of firmware files in one directory on the firmware server.
Allow DHCP Option 43 and Option 66 to Override Server	Obtains configuration and upgrade server's information from DHCP server using options 66 and 43. Note: If DHCP Option 66 is enabled, the base will attempt downloading the firmware file from the server URL provided by DHCP, even though Firmware Server Path is left blank.
Automatic Upgrade	Specifies when the firmware upgrade process will be initiated; there are 4 options: <ul style="list-style-type: none">● Yes, check for upgrade at random every X days: User needs to specify a period in days.● No: Base station will only do upgrade once at boot up.● Check every X minutes: User needs to specify a period in minutes.● Check every day: User needs to specify "Hour of the day (0-23)".● Check every week: User needs to specify "Hour of the day (0-23)" and "Day of the week (0-6)". Note: Day of week is starting from Sunday. Default is No.
Firmware Key	Decrypts the firmware file using specified key (32-digit in Hexadecimal) when encrypted.
Handset Firmware	<ul style="list-style-type: none">● Upload: Uploads handset firmware. Reboot the device after uploading to apply and use the new firmware.● Delete: Deletes previously uploaded handset firmware.

	<ul style="list-style-type: none"> ● Automatic Upgrade: Enables automatic upgrade when the handset detects the new firmware.
Provisioning	
XML Config File Password	Decrypts XML configuration file when encrypted. The password used for encrypting the XML configuration file is using OpenSSL.
HTTP/HTTPS User Name	Enters user name to authenticate with HTTP/HTTPS server.
HTTP/HTTPS Password	Enters password to authenticate with HTTP/HTTPS server.
Always send HTTP Basic Authentication Information	Includes configured user name and password in HTTP request before receiving authentication challenge from the server. Default is No.
Verify host when using HTTPS	Verifies host name in server certificate when using HTTPS. Default is Yes
Provisioning via	Choose the method that the base station uses to request handset ipci config file. Can use TFTP, HTTP,FTP,FTPS or HTTPS.
Config Server Path	Sets IP address or domain name of configuration server. The server hosts a copy of the configuration file to be installed on the DP75x. Default is fm.grandstream.com/gs . Note: Make sure to not prepend address with "http://" or any other protocol.
Config File Prefix	Checks if configuration files are with matching prefix before downloading them. This field enables user to store different configuration files in one directory on the provisioning server.
Config File Postfix	Checks if configuration files are with matching postfix before downloading them. This field enables user to store different configuration files in one directory on the provisioning server.
Enable Handset Config Upgrade	Checks to allow handset config upgrade for handset related settings. Default is No.
Handset Config File Prefix	If configured, only the handset configuration file with the matching encrypted prefix will be downloaded and flashed into the device.
Handset Config File Postfix	If configured, only the handset configuration file with the matching encrypted postfix will be downloaded and flashed into the device.
Allow DHCP Option 43 and Option 66 to Override Server	Obtains configuration and upgrade server's information from DHCP server using options 66 and 43. Note: If DHCP Option 66 is enabled, the DP75x will attempt downloading the firmware file from the server URL provided by DHCP, even though Config Server Path is left blank.

Allow DHCP Option 120 to Override SIP Server	Obtains configuration and update SIP server information from DHCP server using options 120. Note: If DHCP option 120 is enabled, the sip server setting can be changed for profile 1.
3CX Auto Provision	Sends multicast "SUBSCRIBE" message for provisioning at booting stage, used for PnP (Plug-and-Play) configuration. Default is Yes.
Disable SIP NOTIFY Authentication	Device will not challenge NOTIFY with 401 when set to "Yes". Default setting is "No".
Automatic Provisioning	Specifies when provisioning process will be initiated; there are 4 options: <ul style="list-style-type: none">● No: Base station will only request configuration files once at boot up.● Check every X minutes: User needs to specify a period in minutes.● Check every day: User needs to specify "Hour of the day (0-23)".● Check every week: User needs to specify "Hour of the day (0-23)" and "Day of the week (0-6)". Note: Day of week is starting from Sunday. Default is No.
Hour of the Day (0-23)	Defines the hour of the day to check the HTTP/TFTP server for configuration file changes. Default is 1
Day of the Week (0-6)	Defines the day of the week to check HTTP/TFTP server for configuration file changes. Default is 1
Authenticate Conf File	Authenticates configuration file before being accepted. This protects the device configuration from unauthorized modifications. Default is No.
Upload Device Config	Uploads manually device configuration (XML and TXT formats are supported) to base station.
Device Config (TXT)	Downloads actual device configuration file in .txt format.
Device Config (XML)	Downloads default device configuration file in .xml format.
Backup Configuration	Generates an XML config file storing all current configuration after pressing Backup Settings and display list of backup files available (users need to wait a few seconds and refresh the provisioning page to display the backup files). Maximum of 10 backup files are supported and when it reaches 10 entries, this feature will be disabled. Note: Click on Download to download the specific backup or Delete to remove all the backup files.
Web/SSH Access	
User Password	Configures user level password. Case sensitive and max. length of

	30 characters.
Confirm Password	Configures the new user password again to confirm the new password.
Admin Password	Configures admin level password. Case sensitive and max length is 30 characters.
Confirm Password	Configures the new user password again to confirm the new password.
Access Control Lists	<ul style="list-style-type: none"> ● White list for WAN side: If white list exists, then only these IP addresses are allowed to web and SSH access. ● Black list for WAN side: If black list exists and white list is empty, then only these IP addresses are not allowed to web and SSH access
TR-069	
Enable TR-069	Enables / Disables TR-069 service. The default is No. Note: TR-069 supports Extensible Messaging and Presence Protocol (XMPP) connections.
ACS URL	Specifies URL of TR-069 Auto Configuration Server. (e.g., http://acs.mycompany.com), or IP address.
ACS Username	Enters username to authenticate to ACS.
ACS Password	Enters password to authenticate to ACS.
Periodic Inform Enable	Sends periodic inform packets to ACS. Default is No.
Periodic Inform Interval	Configures to sends periodic “Inform” packets to ACS based on specified interval.
Connection Request Username	Enters username for ACS to connect to the base station.
Connection Request Password	Enters password for ACS to connect to the base station.
Security Settings - Web / SSH	
HTTP Web Port	Customizes HTTP port used to access base station web UI. Default is 80.
HTTPS Web Port	Customizes HTTPS port used to access base station web UI. Default is 443.
Disable SSH	Disables SSH access. Default is No.
SSH Port	Customizes SSH access port. Default is 22.
Security Settings - SIP TLS Settings	
SIP TLS Certificate	Specifies SSL certificate used for SIP over TLS in X.509 format. Base station has built-in private key and SSL certificate. Max

	allowed length 8192.
SIP TLS Private Key Password	Specifies SSL certificate key used for SIP over TLS in X.509 format. Base station has built-in private key and SSL certificate.
SIP TLS Private Key Password	Specifies SSL certificate key password used for SIP over TLS in X.509 format.
Security Settings - RADIUS	
Primary RADIUS Server	Defines the primary RADIUS server (Remote Authentication Dial-In User Service) to authenticate dial-in users and authorize their access to requested system or service.
Primary RADIUS Authentication Port	Uses specified port for authentication with the primary RADIUS server. Default is 1812.
Primary RADIUS Account Port	Specifies port to be used for the primary RADIUS account. Default is 1813.
Primary RADIUS Server Secret	Enters secret string to be used to authenticate the RADIUS connection to the primary server. It should match RADIUS configuration.
Secondary RADIUS Server	Sets IP or FQDN of the secondary RADIUS server. In case primary radius server becomes unusable, the secondary will take role and manage credit resources in the network.
Secondary RADIUS Authentication Port	Uses specified port for authentication with the secondary RADIUS authentication. Default is 1812.
Secondary RADIUS Account Port	Specifies port to be used for the secondary RADIUS account. Default is 1813.
Secondary RADIUS Sever Secret	Enters secret string to be used to authenticate the RADIUS connection to the secondary server. It should match RADIUS configuration.
RADIUS Timeout	Specifies period of time before request is cancelled if no response. Default is 2.
RADIUS Retry	Specifies amount of retry attempts if RADIUS communication failure. Default is 3.
Security Settings – Device Custom Certificate	
Device Custom Certificate	Configures the certificate used by device during provisioning and web access.
Device Custom Private Key	Configures the private key used by device during provisioning and web access.
Enable Device Custom Certificate	When enables the device will use the custom certificate, otherwise it will use the default certificates. Default is No.
Security Settings - Security	

Validate Server Certificates	Validate server certificates with our trusted list for TLS connections. If set to "No", device will bypass certificate validation (not recommended)
Trusted CA Certificates	
CA Certificate	Upload Trusted CA certificate to use for HTTPS/FTPS server. Up to six CA Certificates can be uploaded. Note: New DigiCert certificates were added with a firmware upgrade to version 1.0.19.2
Load CA Certificates	Configures what certificates to use to authenticate with the server: <ul style="list-style-type: none"> ● Default Certificates (built-in) ● Custom Certificates ● All Certificates
Date and Time	
NTP Server	Defines URL or IP address of the NTP (Network Time Protocol) server. Used by the base to synchronize the date and time. A list of public NTP servers can be found at pool.ntp.org .
NTP Update Interval	Contacts NTP server at specified period of time (in minutes) to obtain the date and time. Default is 60 minutes.
Allow DHCP Option 42 to NTP Server	Obtains NTP server address from a DHCP server using DHCP Option 42; it will override configured NTP Server. If set to "No", the base will use configured NTP server to synchronize time and date even if a NTP server is provided by DHCP server. Default is No.
Time Zone	Selects time zone to define date/time on the base.
Self-Defined Time Zone	Allows users to define their own time zone.
Allow DHCP Option 2 to override time zone	Obtains time zone setting (offset) from a DHCP server using DHCP Option 2; it will override selected time zone. If set to "No", the base station will use selected time zone even if provided by DHCP server. Default is No.
Custom Time Zone Settings	
Custom Time Zones	Enable or disable customized time zone. Default is Disabled.
UTC Offset	Offset is negative for time zone following UTC and positive for time zone leading UTC (-12 to +14). Default is 0.
Second Offset	Offset for second time zone. Offset is negative for time zone following UTC and positive for time zone leading UTC (-12 to +14). Default is 0.
DST Type	Set Daylight Savings Time by day or by week. Default is by week.

Start & End Times	Starting and ending times for the time zone. Default Start is 2:0 ; Default End is 2:0.
Time zone settings by week	<ul style="list-style-type: none"> ● Start & End Months: Starting and ending months for the time zone. Default Start is April; Default End is September. ● Start & End settings by week : Starting and ending settings by week for the Default Start is Sunday, Week 1 ; Default End is Sunday, Week1.
Time zone settings by day	<ul style="list-style-type: none"> ● Start & End settings by day: Starting and ending settings by day (0-365) for the time zone. Default Start is 1 ; Default End is 1.
Manual Time Settings	
Manual Time	Disables/Enables manual time settings. Default is Disabled.
Year / Month / Day	Set the Year (2016-2037), Month (1-12) and Day (1-31) manually.
Hour : Minute	Enter hour (0-23), Minute (0-59) manually
Syslog	
Syslog Protocol	Allow sending syslog through secured TLS protocol to syslog server. Default is UDP. Note: CA verification is required
Syslog Server	Sets IP address or URL of system log server. The server collects system log information from the base station. User may configure the Syslog port by adding it after the Syslog Server address. When configured, the Syslog messages will be sent to this port instead of the default syslog port. Default is 514.
Syslog Level	<p>Selects log level; the level is one of DEBUG, INFO, WARNING, ERROR, EXTRA DEBUG (default is NONE). Syslog messages are sent based on the following events:</p> <ol style="list-style-type: none"> 1. product model/version on boot up (INFO level) 2. NAT related info (INFO level) 3. sent or received SIP message (DEBUG level) 4. SIP message summary (INFO level) 5. inbound and outbound calls (INFO level) 6. registration status change (INFO level) 7. negotiated codec (INFO level) 8. Ethernet link up (INFO level) 9. SLIC chip exception (WARNING and ERROR levels) 10. memory exception (ERROR level) <p>The Syslog uses USER facility. In addition to standard Syslog payload, it contains the following components:</p> <p><i>GS_LOG: [device MAC address] [error code] error message.</i></p> <p><u>Example:</u> May 19 02:40:38 192.168.1.14 GS_LOG: [00:0b:82:00:a1:be][000] Ethernet link is up</p>

Print SIP in Syslog	Includes full SIP messages in syslog.
Packet Capture	
Status	Displays packet capture status. When user starts to capture trace file, it will show “RUNNING” status, otherwise, it will show “STOPPED”.
With RTP Packets	Defines whether packet capture file contains RTP or not. Default setting is No.
With Secret key information	If set to “Yes, the packet capture will include secret key to decrypt the capture TLS packets. By default, it is enabled.
Factory Reset	
Force Reboot	Kills active processes and forces the reboot of DP75x base station.
Configure Web UI Button	<p>Specifies the type of reset to perform via the Web UI reset button:</p> <p>- There are 3 reset type for Web UI button:</p> <ol style="list-style-type: none"> 1. Full Factory Reset: Reset all the settings 2. NVRAM Settings Only: Reset all the settings except subscription information, so the handset will stay in subscribed after reset, but all the other settings like account info, call settings, audio settings, etc., will be reset. 3. DECT Settings Only: Reset only the subscription (wipe out all the subscription information), but keep all the other settings like account, SIP settings. <p>Press Reset button to reset settings based on the reset type selected.</p>
Configure Hardware Button	<p>Specifies the type of reset to perform via hardware button:</p> <p>- There are 4 reset types for hardware button:</p> <ol style="list-style-type: none"> 1. Full Factory Reset: Reset all the settings. 2. NVRAM Settings Only: Reset all the settings except subscription information, so the handset will stay in subscribed after reset, but all the other settings like account info, call settings, audio settings, etc. will be reset. 3. DECT Settings Only: Reset only the subscription (wipe out all the subscription information), but keep all the other settings like account, SIP settings. 4. Disabled: Disable the hardware button to factory reset the base for security purpose
Automatic Reboot	
Automatic Reboot	<p>No: if selected the automatic reboot will not be configured</p> <p>Yes, reboot daily: if selected, the automatic reboot will be performed daily</p> <p>Yes, reboot every week on: select the day in which you want the automatic reboot to be performed</p> <p>Yes, reboot every month on day: select the day in which you want the automatic reboot to be performed</p>
Support - Support Documentation	

Online Support	Redirects users to tools page and DP7xx product pages available on Grandstream official website.
Offline Support	Allows users to download the drilling templates.
Support - Configuration Tools	
Download Default Device Configuration	Downloads the default device configuration file in .txt and .XML formats.
Download UCM Zero Config Template	Download the zero config templates files for UCM firmware version before and after 1.0.10.39.
Support - Debug Tools	
Remote Log Submission - Terms & Conditions	<ul style="list-style-type: none"> ● Agree to terms?: By clicking the submit button, you agree to terms and conditions for submitting debug logs and allow the device to send these files to Grandstream to be used for troubleshooting purposes. Note: Grandstream will not collect any information without customers acknowledged and permissions. ● Email Address: Configures email field for core collection tools. Users can leave a contact email to get feedbacks. ● Comments: Includes a comment with information regarding the use of the device when the problem occurred. As an alternative to the device submitting the files, you may download the files below and submit them to Grandstream manually.
Debug Log Files	Kills phone control process on base station and generates core file and other debug information and also it allows users to delete the generated log files. Reboot required to restart process.
Handset Notification	Notifies handset when a debug file is available after recovery. Default is No.

Table 13: Maintenance Page Definitions

Phonebook Page Definitions

Global Phonebook XML Settings	
Global Phonebook Type	Selects type of global phonebook to use. If set to XML, DP750 will use the configuration in Global Phonebook XML Settings page. If set to LDAP, DP750 will use configuration in Global Phonebook LDAP Settings page.
Enable Automatic XML Phonebook Download	Sends periodic requests to download XML Phonebook via HTTP, HTTPS, or TFTP.
HTTP/HTTPS User Name	Enters user name to authenticate with HTTP/HTTPS server.
HTTP/HTTPS Password	Enters password to authenticate with HTTP/HTTPS server.

Phonebook XML Server Path	Indicates server path to download XML phonebook file. This field could be IP address or URL, with up to 256 characters.
Phonebook Download Interval	Sets interval to send XML phonebook download requests (in minutes). If set to 0, automatic download is disabled. Valid range is 5 to 720. Default is 5 minutes.
Import XML Phonebook	Upload: Uploads manually global XML phonebook file to the base station. Delete: Clears global XML phonebook file in the base station.
Export XML Phonebook	Downloads global XML phonebook from the base station in .xml format.
Broadsoft XSI	
XSI	
Server	Configure the BroadWorks Xsi server URI. If the server uses HTTPS, please add the header "HTTPS" ahead of the Server URI. For instance, "https://SERVER_URI".
Port	Configure the BroadWorks Xsi server port. The default port is 80. If the server uses HTTPS, please configure 443.
XSI Authentication Type	This feature allows users to configure the deployment path for Broadsoft XSI Actions. If it is empty, the path "com.broadsoft.xsiactions" will be used
Login Credentials	
Login Username	Configure the Username for the BroadWorks XSI server.
Login Password	Configure the password for the BroadWorks XSI server.
SIP Credentials	
SIP Username	Configure SIP Username for the BroadWorks XSI server.
SIP User ID	Configure SIP User ID for the BroadWorks XSI server.
SIP Password	Configure SIP Password for the BroadWorks XSI server.
Network Directories	
Enable/Disable and choose the name of the following types: Group Directory; Enterprise Directory; Group Common; Enterprise Common; Personal Directory.	
Global Phonebook LDAP Settings	
Global Phonebook Type	Selects type of global phonebook to use. If set to XML, DP750 will use the configuration in Global Phonebook XML Settings page. If set to LDAP, DP750 will use configuration in Global Phonebook LDAP Settings page.
LDAP protocol	Chooses LDAP or LDAPS (LDAP over TLS) protocol. Default is

	LDAP.
Server Address	Configures IP address or domain name of the LDAP server.
Port	Determines LDAP server port. Default is 389 .
Base	Indicates the location in the directory where the search is requested to begin. Example: dc=grandstream, dc=com ou=Boston, dc=grandstream, dc=com
User Name	Binds "Username" for querying LDAP servers. Some LDAP servers allow anonymous binds in which case the setting can be left blank.
Password	Binds "Password" for querying LDAP servers. The field can be left blank if the LDAP server allows anonymous binds.
LDAP Filter	LDAP filter to limit which contacts are fetched from the server. LDAP statement to limit which contacts are fetched from the server. Statement must be in parenthesis.
LDAP Version	Selects LDAP protocol version to send bind requests. Default is Version 3.
First Name Attribute	Defines first name attributes of each record to be returned in the LDAP search result. This field allows users to configure multiple space separated name attributes. Example: gn cn sn description
Last Name Attribute	Defines last name attributes of each record to be returned in the LDAP search result. This field allows users to configure multiple space separated name attributes. Example: gn cn sn description
Work Number Attribute	Specifies which LDAP attribute represent the contact's work number. Must be in number attributes on LDAP server.
Home Number Attribute	Specifies which LDAP attribute represent the contact's home number. Must be in number attributes on LDAP server.
Mobile Number Attribute	Specifies which LDAP attribute represent the contact's mobile number. Must be in number attributes on LDAP server.
Max. Hits	Specifies maximum number of results to be returned by LDAP server. If set to 0, server will return all search results. Valid range is 1 to 3000. Default is 500 .
Search Timeout	Sets interval (in seconds) for the server to process the request and return search results to the client. Default is 30 seconds.
Private Phonebook Settings	

Phonebook Name	Defines private phonebook name.
Import XML Phonebook	Upload: Uploads manually private XML phonebook file to the base station. Delete: Clears private XML phonebook file in the base station
Export XML Phonebook	Downloads private XML phonebook from the base station in .xml format.

Table 14: Phonebook Page Definitions

Change Base Station Admin PIN code

For security reasons, advanced settings in DP750 base station cannot be accessed from DP720 handset except if Admin PIN code is provided. By default, Admin PIN code is 0000.

We strongly recommend changing your Admin PIN code following below steps:

1. Access the Web GUI of your DP750 using the admin's username and password. (Starting HW version 1.7A the default admin username is 'admin' while the admin password is the random password that can be found on the sticker at the back of the unit. For lower hardware versions; the default username and password are: admin/admin).
2. Press Login to access your settings.
3. Go to DECT → General Settings tab.
4. Enter your new Admin PIN Code (only digits accepted) in appropriate field.
5. Press Save and Apply to save your settings.

The screenshot shows the 'DECT General Settings' page. On the left, there is a sidebar with menu items: 'General Settings' (selected), 'SIP Account Settings', 'Handset Line Settings', and 'Handset Settings'. The main content area is titled 'General Settings' and contains several configuration options:

- 'Base Station Name' with a text input field containing 'DP750_870884'.
- 'Admin PIN Code' with an empty text input field, which is highlighted with a red rectangular border.
- 'Enable Repeater Mode' with radio buttons for 'No' and 'Yes' (selected).
- 'Enable Repeater Management' with radio buttons for 'No' and 'Yes' (selected).
- 'Clear Call Logs' with a blue 'Delete' button.

Figure 15: Admin PIN Code

Register DP720 Handset to DP750 Base Station

1. On DP750 Base station, press and hold the Radio/Page button for 7 seconds until the Radio icon starts blinking to start Subscription process. Or Access web UI, and press **Subscribe** icon  to **Open Subscription**.
2. On DP720, press "Subscribe" softkey if available on the main screen or access **Menu →Registration → Register** while the DP750 Radio icon is blinking.
Note: "Subscribe" softkey appears only if DP720 is not registered to any DP750 base station.
3. Select **BaseX** (X=1-4) corresponding to the desired base station DP750, then press **Subscribe**.
4. The DP720 will search for nearby base stations and will display the RFPI code and Base station name of the discovered DP750.
5. Press **Subscribe** to pair with the displayed DP750.
6. The DP720 will display **Easy Pairing** on the LCD and play an audible buzz when successful. Then it will return to the home screen, displaying the handset name and number assigned by the registered base station.

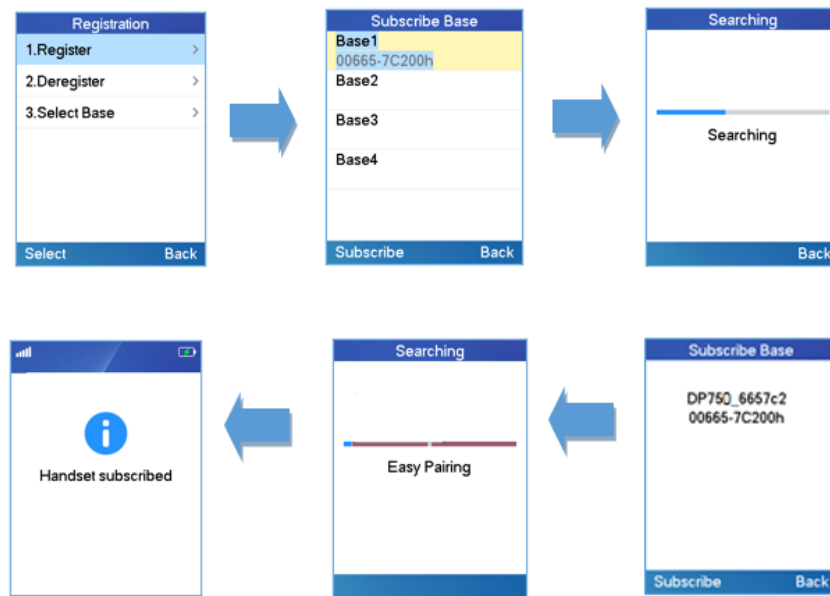

Figure 16: Registration Process

Using DP720 with Multiple DP750 Base Stations

DP720 is able to be registered to up four different DP750 base stations.

Registering DP720 to an additional DP750 base station

Considering DP720 is previously registered to an initial base station, please follow below steps to register a handset to an additional base station:

1. Press **Menu** (left softkey or the selection key) to bring up operation menu.
2. Use arrow keys to reach **Registration** and select **Register**.
3. Navigate to an unsubscribed base using arrow keys, and click on **Subscribe**.
4. Make sure that the subscription is opened on the new base station.



Figure 17: Multiple Base Stations Registration

Switching Between Different Base Stations

1. Press "Menu" (left softkey or the selection key) to bring up operation menu.
2. Use arrow keys to reach **Registration**.
3. Navigate to **Select Base** using arrow keys.
4. Select the desired base station and press **Select**.



Registration	
1.Register	>
2.Deregister	>
3.Select Base	>

Select	Back
--------	------

Figure 18: Switching Between Base Stations

Unregister the DP720

o Using DP720 Handset:

1. On DP720, press "Menu" (left softkey  or the selection key ) to bring up operation menu.
2. Press arrow keys to move the cursor to **Registration**, then press "Select" (left softkey).
3. Navigate to **Deregister**.
4. Select the Handsets to be unregistered and press "Deregister" (left softkey).
5. Enter the system PIN code (default: 0000).
6. Press "Done" (left softkey) to confirm or "Back" (right softkey) to cancel.

o Using DP750 Base Station UI:

1. Access DP750 Web Interface.
2. Go to **Status → DECT Base Status**.
3. Locate the handset to unregister and press "**Unsubscribe**" button.

Version 1.0.7.5

Status

Account Status

DECT Base Status

Line Options

Network Status

System Info

DECT Base Status

Base Station Name	DP750_870880
Base DECT FW Version	CMBS 4.00 Build 123(0x037b)
Base DECT RF Region	UNKNOWN
Base DECT RFPI Address	02C344ED68

Global Functions

Unsubscribe Handsets [Unsubscribe All](#)

Upgrade Handsets [Upgrade All](#)

Handset Status

Handset Name	IPEI		Page	Unsubscribe	HS Firmware	Upgrade	RAM Dump
HS1	HS1		Page	Unsubscribe	1.0.4.2	Upgrade	
HS2	HS2		Page	Unsubscribe	1.0.4.10	Upgrade	
HS3	HS3		Page	Unsubscribe	1.0.6.4	Upgrade	
HS4	HS4	NOT SUBSCRIBED					
HS5	HS5	NOT SUBSCRIBED					

Locating a DP720 Handset from DP750 Base station

In some situations, you may have a DP720 handset incorrectly positioned and you don't know its current location. You can locate a DP720 handset from his registered DP750 base station using below steps:

Locate via DP750 Web UI

1. Access the Web GUI of your DP750 using the admin's username and password. (Starting HW version 1.7A the default admin username is 'admin' while the admin password is the random password that can be found on the sticker at the back of the unit. For lower hardware versions; the default username and password are: admin/admin).
2. Press Login to access your settings and navigate to Status → DECT Base Status tab.
3. Choose which handset to locate and press its corresponding Page button.
4. A paging call will be received on the selected DP720 handset.
Note: If you press **Page All** icon , all registered DP720 handsets will be receiving paging call.
5. Once located, you can press any key on the handset or press **Page** or **Page All** to end paging call.

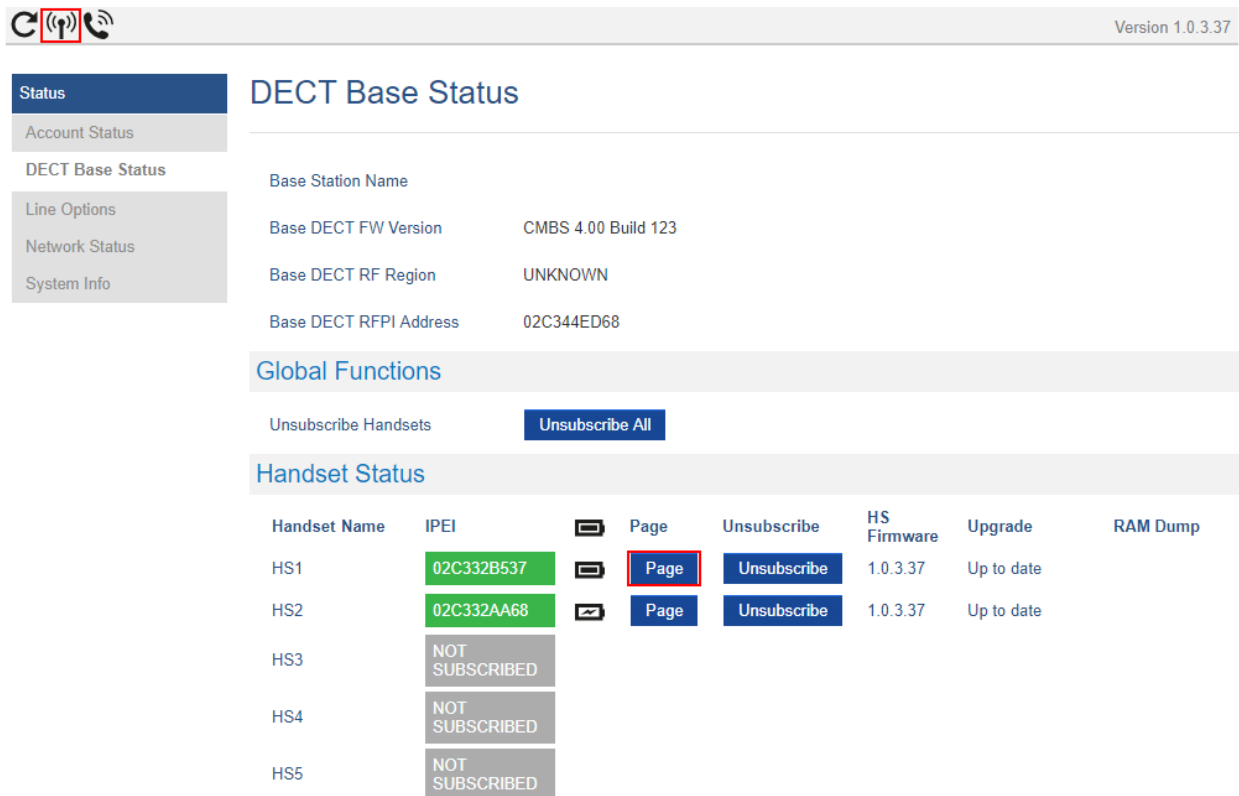

Version 1.0.3.37

Status

- Account Status
- DECT Base Status**
- Line Options
- Network Status
- System Info

DECT Base Status

Base Station Name

Base DECT FW Version: CMBS 4.00 Build 123

Base DECT RF Region: UNKNOWN

Base DECT RFPI Address: 02C344ED68

Global Functions

Unsubscribe Handsets [Unsubscribe All](#)

Handset Status



Handset Name	IPEI		Page	Unsubscribe	HS Firmware	Upgrade	RAM Dump
HS1	02C332B537		Page	Unsubscribe	1.0.3.37	Up to date	
HS2	02C332AA68		Page	Unsubscribe	1.0.3.37	Up to date	
HS3	NOT SUBSCRIBED						
HS4	NOT SUBSCRIBED						
HS5	NOT SUBSCRIBED						

Figure 20: Locate Handset via Web UI

Locate via DP750 Base station

1. On DP750 Base station back side, press **Radio/Page** button



2. All registered handsets will receive Paging call.
3. Once located, you can end the paging calling by pressing any key on the handsets or by pressing again **Radio/Page** button.

Register a SIP Account

DP750 supports up to 10 SIP accounts, 5 handsets. Each Handset can be configured up to 10 accounts. Please be aware that line settings will be affected by DID settings (hunting group settings) in “DECT – SIP Account Settings”.

Register Account via Web User Interface

1. Access the Web GUI of your DP750 using the admin’s username and password. (Starting HW version 1.7A the default admin username is ‘admin’ while the admin password is the random password that can be found on the sticker at the back of the unit. For lower hardware versions; the default username and password are: admin/admin).
2. Press Login to access your settings and navigate to Profiles tab and select a profile to use.
Note: DP750 supports up to 4 profiles. A profile is a set of settings including general settings, network settings, SIP setting, audio setting, call settings and ring tones, etc.
A profile can be used with different SIP accounts.
3. In **General Settings**, set the following:
 - **Profile Active** to **Yes**.
 - **SIP Server** field with your SIP server IP address or FQDN.
 - **Failover SIP Server** with your Failover SIP Server IP address or FQDN. Leave empty if not available.
 - **Prefer Primary SIP Server** to **No** or **Yes** depending on your configuration. Set to **No** if no Failover SIP Server is defined. If “**Yes**”, account will register to Primary SIP Server when failover registration expires.
 - **Outbound Proxy** with your Outbound Proxy IP Address or FQDN. Leave empty if not available.
 - **Voice Mail Access Number** Allows users to access voice messages. This value is usually the VM portal access number. For example: configuring the access code to “*97,,password” will automatically dial the Voice Mail box and enter the password.
For more information, related to above options please refer to [Technical Information table](#)
4. Press **Save and Apply** to save your configuration.

The screenshot shows the 'General Settings' page for 'Profile 1'. On the left, a sidebar lists 'Profiles' with 'Profile 1' selected, and other settings categories like 'Network Settings', 'SIP Settings', 'Audio Settings', 'Call Settings', and 'Profile 2-4'. The main area contains the following settings:

- Profile Active:** Radio buttons for 'No' and 'Yes' (selected).
- Profile Name:** Text input field containing 'profile1'.
- SIP Server:** Text input field containing 'Sip.mycompany.com'.
- Failover SIP Server:** Empty text input field.
- Prefer Primary SIP Server:** Radio buttons for 'No' (selected) and 'Yes'.
- Outbound Proxy:** Empty text input field.
- Voice Mail Access Number:** Empty text input field.

At the bottom right, there are three buttons: 'Save', 'Save and Apply', and 'Reset'.

Figure 21: SIP Settings

5. Go to **DECT →SIP Account Settings**
6. Configure your SIP details in desired account:
 - **Account:** Select Account row to configure (Account 1 – Account 10).
 - **SIP User ID:** User account information, provided by VoIP service provider (ITSP). Usually in the form of digit similar to phone number or actually a phone number.
 - **Authenticate ID:** SIP service subscriber’s Authenticate ID used for authentication. Can be identical to or different from SIP User ID.
 - **Password:** SIP service subscriber’s account password to register to SIP server of ITSP. For security reasons, the password will field will be shown as empty.

- **Name:** Any name to identify this specific user.
- **Profile:** Select the corresponding Profile ID (1/2/3/4).
- **HS Mode:** Assign the account to specific handset (HS1, HS2...) or hunting group mode.
- **Active:** Set to **Yes**. If set to **No**, account is disabled and will not register.

7. Press **Save and Apply** to save your configuration.

Account	SIP User ID	Authenticate ID	Password	Name	Profile	HS Mode	Active
Account 1	2000	2000	*****	2000	Profile 1	HS 1	<input type="radio"/> No <input checked="" type="radio"/> Yes
Account 2	2001	2001	*****	2001	Profile 1	HS 2	<input type="radio"/> No <input checked="" type="radio"/> Yes
Account 3	2002	2002	*****	2002	Profile 1	HS 3	<input type="radio"/> No <input checked="" type="radio"/> Yes
Account 4	2003	2003	****	2003	Profile 1	Circular	<input type="radio"/> No <input checked="" type="radio"/> Yes
Account 5					Profile 1	Circular	<input type="radio"/> No <input checked="" type="radio"/> Yes
Account 6					Profile 1	Circular	<input type="radio"/> No <input checked="" type="radio"/> Yes
Account 7					Profile 1	Circular	<input type="radio"/> No <input checked="" type="radio"/> Yes
Account 8					Profile 1	Circular	<input type="radio"/> No <input checked="" type="radio"/> Yes
Account 9					Profile 1	Circular	<input type="radio"/> No <input checked="" type="radio"/> Yes
Account 10					Profile 1	Circular	<input type="radio"/> No <input checked="" type="radio"/> Yes

Figure 22: SIP Accounts Settings

After applying your configuration, your phone will register to your SIP Server.

You can verify if your DECT phone has registered with your SIP server from your DP750 web interface under **Status** → **Account Status** (a green background with Yes under SIP Registration column for corresponding account indicates the account(s) has been successfully registered).

Account	SIP User ID	SIP Server	SIP Registration	HS Mode	HS1	HS2	HS3	HS4	HS5
Account 1	2000	192.168.5.250	YES	HS 1					
Account 2	2001	192.168.5.250	YES	HS 2					
Account 3	2002	192.168.5.250	YES	HS 3					
Account 4	2003	192.168.5.250	YES	Circular					
Account 5			N/A						
Account 6			N/A						
Account 7			N/A						
Account 8			N/A						
Account 9			N/A						
Account 10			N/A						

Figure 23: Account Status

Multiple Lines and Hunting Groups

The DP750 Base Station has the ability to assign 10 lines to each registered DP720 handset (Up to 5 Handsets) to receive/make calls.

When a handset has many lines configured, users can select specific line for outgoing calls using **Outgoing Default Line** feature.

For incoming calls, users can choose either to redirect them to a specific handset or to many using Hunting Group feature so to have the same phone number and incoming calls will be distributed in a Linear, Circular or Parallel manner among the handsets active in that Hunting Group. The number of hunting groups is limited by the number of SIP accounts registered to the base station (up to 10 accounts).

Hunting group feature is mainly used in office, warehouse and call center environments to distribute incoming calls in the best way depending on the type of hunt group.

In order to configure hunting groups for DP720 Handsets registered to the Base, users need first to register SIP accounts on DP750 Base Station **SIP Account Settings** and then assign accounts accordingly as lines for DP720 Handsets **Handset Line Settings**.

Handset Line Settings

This section will describe how to assign lines for each DP720 Handset for making calls.

1. Access the Web GUI of your DP750 using the admin's username and password. (Starting HW version 1.7A the default admin username is 'admin' while the admin password is the random password that can be found on the sticker at the back of the unit. For lower hardware versions; the default username and password are: admin/admin).
2. Press Login to access your settings.
3. Go to **DECT → Handset Line Settings**, and assign to Handsets the SIP accounts already configured. Each handset can be configured to use up to 10 sip accounts.

	LINE 1	LINE 2	LINE 3	LINE 4	LINE 5	LINE 6	LINE 7	LINE 8	LINE 9	LINE 10
HS 1	2002 ▼	2003 ▼	2004 ▼	2005 ▼	2006 ▼	2007 ▼	2008 ▼	2009 ▼	2010 ▼	2011 ▼
HS 2	2003 ▼	2005 ▼	None ▼	2007 ▼	None ▼	None ▼	2006 ▼	None ▼	None ▼	None ▼
HS 3	2005 ▼	2002 ▼	2004 ▼	None ▼	2007 ▼	2008 ▼	None ▼	None ▼	2006 ▼	None ▼
HS 4	2004 ▼	2006 ▼	None ▼	2005 ▼	2003 ▼	2007 ▼	None ▼	None ▼	None ▼	None ▼
HS 5	None ▼	2006 ▼	2010 ▼	None ▼	None ▼	2007 ▼	None ▼	None ▼	None ▼	None ▼

Save Save and Apply Reset

Figure 24: Handset Line Settings

After applying your configuration, **Account Status** page will display the status of handsets along with accounts status. Each column shows one HS; each row shows if the account is assigned to a HS.

For example: If the account 2, 4, 5, and 6 are assigned to the HS2, the column of HS2 will have cells 2, 4, 5 and 6 in green background, and account 1, 3, 7, 8, 9 and 10 are in gray background. If a line is being used it will be blinking in a green / white background.

- Account Status
- DECT Base Status
- Line Options
- Network Status
- System Info

Account	SIP User ID	SIP Server	SIP Registration	HS Mode	HS1	HS2	HS3	HS4	HS5
Account 1	2002	192.168.5.250	YES	HS 1					
Account 2	2003	192.168.5.250	YES	Circular					
Account 3	2004	192.168.5.250	YES	Circular					
Account 4	2005	192.168.5.250	YES	Circular					
Account 5	2006	192.168.5.250	YES	Circular					
Account 6	2007	192.168.5.250	YES	Circular					
Account 7	2008	192.168.5.250	YES	Circular					
Account 8	2009	192.168.5.250	YES	Circular					
Account 9	2010	192.168.5.250	YES	Circular					
Account 10	2011	192.168.5.250	YES	Circular					

Figure 25: Account Status – Line Status

Outgoing Default Line

Preferences

Outgoing Default Line >

Auto Answer Disabled

Off-Cradle Pickup Disabled

On-Cradle Hangup Disabled

Mute as DND Disabled

Disable Busy Tone Disabled

Select Back

Outgoing Default Line

1.3002 ✓

2.3004

3.3006

Select Back

When a Handset is configured with more than one line, users can change the default outgoing line on DP720 Handset using keypad **Menu** → **Preferences** → **Outgoing Default Line**, see screenshot above

Hunting Groups

DP750 supports 3 types of hunting groups as described below:

In the examples below, we consider that all handsets are in same hunting group and only the type of hunting group differs.

- **Circular:** The base station will note which handset answered the last call, and forward the call to the next available handset in round-robin fashion.

In the example below; the 1st incoming call was sent to HS1 since all handsets were available; 2nd incoming call will be sent to HS2 since previous call was answered by HS1 and HS2 is the next available handset in the list; 3rd will be sent to HS4 since HS2 was the last one answering the call and HS3 is busy making an outgoing call (if HS3 was available, the call will be sent to HS3).

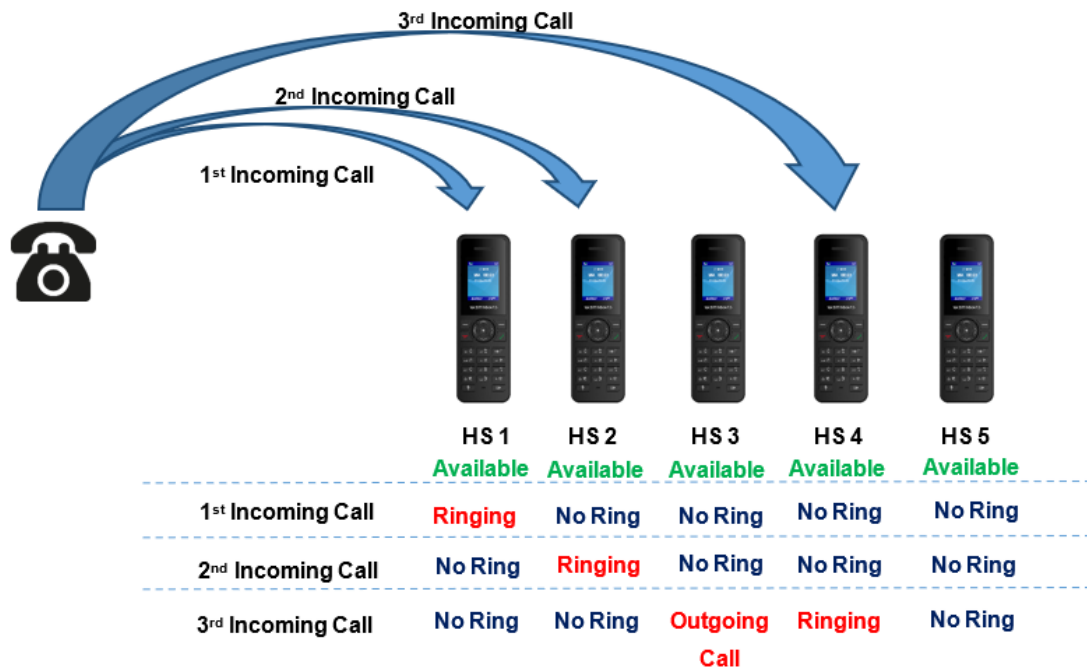

- **Linear:** The base station will distribute the call in predefined order from the lowest-numbered available handset, if no answer within ring timeout, the call will be sent to next available handset in sequence. This mode is also called “serial hunting”.

In the example below; all handsets are available, the incoming call will be sent to HS1 since it’s the lowest-numbered available handset, if no answer within ring timeout, the call will be sent to HS2 since it’s the next available lowest-numbered handset, and same applies for HS3 and etc.



- **Parallel:** In this mode, all phones ring concurrently. If one phone answers, the remaining available phones can make new outgoing calls.

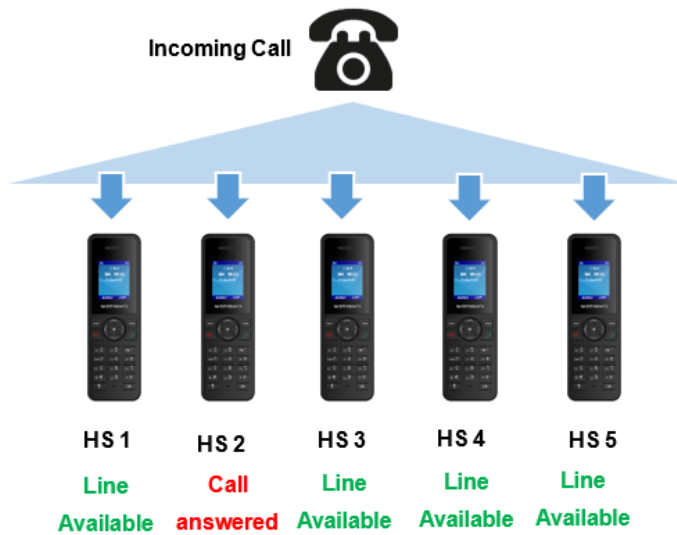

This section will describe how to configure hunting groups for incoming calls:

Below steps are considering that SIP accounts were previously registered.

1. Access the Web GUI of your DP750 using the admin's username and password. (Starting HW version 1.7A the default admin username is 'admin' while the admin password is the random password that can be found on the sticker at the back of the unit. For lower hardware versions; the default username and password are: admin/admin).
2. Press **Login** to access your settings.
3. Go to **DECT → SIP Account Settings**.
4. Set **HS Mode** depending on your needs to configure your hunting groups.
5. Press **Save and Apply** to save your settings.

Example:

In the example below Account 3 (2002) is assigned to HS1, HS3, HS4 and HS5, and the hunting group (HS Mode) is set to Parallel, so incoming calls to that account will make HS1, HS3, HS4 and HS5 ring simultaneously, and when one of the Handsets answers, the remaining three will be able to make or receive new calls using that account.

DECT

General Settings

SIP Account Settings

Handset Line Settings

Handset Settings =

HS1 Settings

HS2 Settings

HS3 Settings

HS4 Settings

HS5 Settings

SIP Account Settings

Account	SIP User ID	Authenticate ID	Password	Name	Profile	HS Mode	Active
Account 1	2000	2000		2000	Profile 1 ▼	HS 1 ▼	<input type="radio"/> No <input checked="" type="radio"/> Yes
Account 2	2001	2001		2001	Profile 1 ▼	Linear ▼	<input type="radio"/> No <input checked="" type="radio"/> Yes
Account 3	2002	2002		2002	Profile 1 ▼	Parallel ▼	<input type="radio"/> No <input checked="" type="radio"/> Yes
Account 4	2003	2003		2003	Profile 1 ▼	HS 2 ▼	<input type="radio"/> No <input checked="" type="radio"/> Yes
Account 5	2004	2004		2004	Profile 1 ▼	HS 3 ▼	<input type="radio"/> No <input checked="" type="radio"/> Yes
Account 6	2005	2005		2005	Profile 1 ▼	HS 4 ▼	<input type="radio"/> No <input checked="" type="radio"/> Yes
Account 7	2006	2006		2006	Profile 1 ▼	Circular ▼	<input type="radio"/> No <input checked="" type="radio"/> Yes
Account 8	2007	2007		2007	Profile 1 ▼	Parallel ▼	<input type="radio"/> No <input checked="" type="radio"/> Yes
Account 9	2008	2008		2008	Profile 1 ▼	HS 2 ▼	<input type="radio"/> No <input checked="" type="radio"/> Yes
Account 10	2009	2009		2009	Profile 1 ▼	Circular ▼	<input type="radio"/> No <input checked="" type="radio"/> Yes

Save
Save and Apply
Reset

Figure 26: Hunting Group Configuration

- Account Status
- DECT Base Status
- DECT Repeater Status
- Line Options
- Network Status
- System Info

Account	SIP User ID	SIP Server	SIP Registration	HS Mode	HS1	HS2	HS3	HS4	HS5
Account 1	2000	192.168.5.250	YES	HS 1					
Account 2	2001	192.168.5.250	YES	Linear					
Account 3	2002	192.168.5.250	YES	Parallel					
Account 4	2003	192.168.5.250	YES	HS 2					
Account 5	2004	192.168.5.250	YES	HS 3					
Account 6	2005	192.168.5.250	YES	HS 4					
Account 7	2006	192.168.5.250	YES	Circular					
Account 8	2007	192.168.5.250	YES	Parallel					
Account 9	2008	192.168.5.250	YES	HS 2					
Account 10	2009	192.168.5.250	YES	Circular					

Figure 27: Hunting Group Status

Configuration via Keypad

To configure the LCD menu using DP720's keypad, follow the instructions below:

- Register the DP720 to DP750. Please see [Register DP720 Handset to DP750 Base Station](#);
- **Enter/Confirm/ selection:** Press the left softkey, right softkey, on-hook key or OK/Select key to enter the selected option, back to last layer or exit;
- **Exit:** Press "right softkey" to exit to the previous menu;
- **Return to Home page:** Press "On-hook" key to exit to the main menu.
- The DP720 automatically exits to main mode with an incoming call, when the phone is off hook or left idle for more than 20 seconds.
- When the phone is in idle, pressing the DOWN navigation key can enter the **Outgoing call log**.

Please refer to [DP720 Handset Menu Structure](#) for more details.

Call Features

The DP750/DP720 supports traditional and advanced telephony features including caller ID, caller ID with caller Name, call forward etc.

Table 15: Call Features

*30	<p>Block Caller ID (for all subsequent calls)</p> <ul style="list-style-type: none"> ○ Off hook the phone; ○ Dial *30.
*31	<p>Send Caller ID (for all subsequent calls)</p> <ul style="list-style-type: none"> ○ Off hook the phone; ○ Dial *31.

*67	<p>Call with Caller ID Blocked (per call)</p> <ul style="list-style-type: none"> ○ Off hook the phone; ○ Dial *67 and then enter the number to dial out.
*82	<p>Call with Caller ID Enabled (per call)</p> <ul style="list-style-type: none"> ○ Off hook the phone; ○ Dial *82 and then enter the number to dial out.
*72	<p>Unconditional Call Forward. To set up unconditional call forward:</p> <ul style="list-style-type: none"> ○ Off hook the phone; ○ Dial *72 and then enter the number to forward the call; ○ Press OK softkey or SEND key.
*73	<p>Cancel Unconditional Call Forward. To cancel the unconditional call forward:</p> <ul style="list-style-type: none"> ○ Off hook the phone; ○ Dial *73; ○ Hang up the call.
*90	<p>Busy Call Forward. To set up busy call forward:</p> <ul style="list-style-type: none"> ○ Off hook the phone; ○ Dial *90 and then enter the number to forward the call; ○ Press OK softkey or SEND key.
*91	<p>Cancel Busy Call Forward. To cancel the busy call forward:</p> <ul style="list-style-type: none"> ○ Off hook the phone; ○ Dial *91; ○ Hang up the call.
*92	<p>Delayed Call Forward. To set up delayed call forward:</p> <ul style="list-style-type: none"> ○ Off hook the phone; ○ Dial *92 and then enter the number to forward the call; ○ Press OK softkey or SEND key.
*93	<p>Cancel Delayed Call Forward. To cancel the delayed call forward:</p> <ul style="list-style-type: none"> ○ Off hook the phone; ○ Dial *93; ○ Hang up the call.

DP750 Phonebook Management

DP750/720 support Private and Shared Phonebooks; both phonebook types can be used at same time:

Private Phonebook

Private phonebook allows you to manage your contacts on each registered handset; each handset can have his own private phonebook with his own contacts. DP750 supports up to 5 private phonebooks.

A private phonebook can be assigned to one or more handsets registered to the base.

The following steps explain how upload your private phonebook and assign it to a specific handset:

1. Access the Web GUI of your DP750 using the admin's username and password. (Starting HW version 1.7A the default admin username is 'admin' while the admin password is the random password that can be found on the sticker at the back of the unit. For lower hardware versions; the default username and password are: admin/admin).
2. Press Login to access your settings and go to Phonebook → Private Phonebook Settings.

Phonebook

- Global Phonebook XML Settings
- Global Phonebook LDAP Settings
- Private Phonebook Settings**

Private Phonebook Settings

Private XML Phonebook 1

Phonebook 1 Name

Import XML Phonebook 1

Export XML Phonebook 1

Private XML Phonebook 2

Phonebook 2 Name

Import XML Phonebook 2

Export XML Phonebook 2

Private XML Phonebook 3

Phonebook 3 Name

Import XML Phonebook 3

Export XML Phonebook 3

Figure 28: Private Phonebook Settings

3. In **Private XML Phonebook X** section (X from 1 to 5):

- o Enter **Phonebook X Name** (default value is PB1 for first handset, PB2 for second handset, etc.).
- o Press **Upload** button to **Import XML Phonebook X**.
- o Browse your computer files and select your desired **phonebook.xml** file.
- o Press **Save and Apply** to save your settings.

4. Go to **DECT → General Settings** tab.

5. In **Handset Settings** section, select your **Handset Phonebook** to assign it to a specific handset as shown below where **PB1** is assigned to **HS1**, **PB2** is assigned to **HS2**...

Handset	Handset Name	Handset Phonebook	Offhook Auto-dial
HS1	<input type="text" value="HS1"/>	<input type="text" value="PB1"/>	<input type="text"/>
HS2	<input type="text" value="HS2"/>	<input type="text" value="PB2"/>	<input type="text"/>
HS3	<input type="text" value="HS3"/>	<input type="text" value="PB3"/>	<input type="text"/>
HS4	<input type="text" value="HS4"/>	<input type="text" value="PB4"/>	<input type="text"/>
HS5	<input type="text" value="HS5"/>	<input type="text" value="PB5"/>	<input type="text"/>

Figure 29: Handset Phonebook Settings

You can assign same Private Phonebook to more than one handset.

For example, we can assign **Handset Phonebook** named **PB1** to **HS1** and **HS2**.

Any change in **PB1** contacts will be applied to both **HS1** and **HS2** private phonebooks.

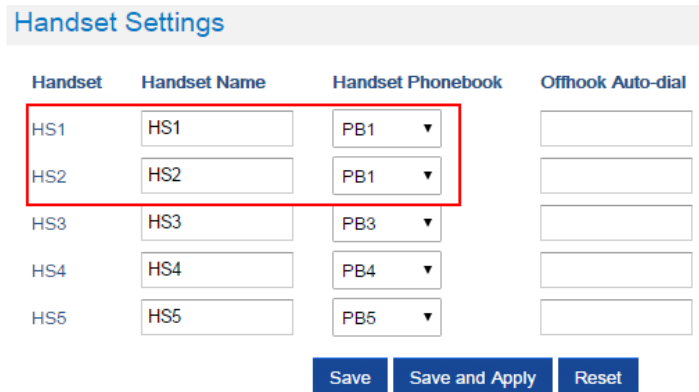

Handset	Handset Name	Handset Phonebook	Offhook Auto-dial
HS1	HS1	PB1	
HS2	HS2	PB1	
HS3	HS3	PB3	
HS4	HS4	PB4	
HS5	HS5	PB5	

Buttons: Save, Save and Apply, Reset

Figure 30: Handset Phonebook Selection

6. Press **Save and Apply** to save your configuration.

After applying your configuration, your DP720 handset will display uploaded phonebook contacts. You can access your private phonebook by pressing **Contacts** on your DP720 handset. You can press Option Softkey in order to view, Create New Contact or Edit Dial if adding changes on a contact number is required before dialing.

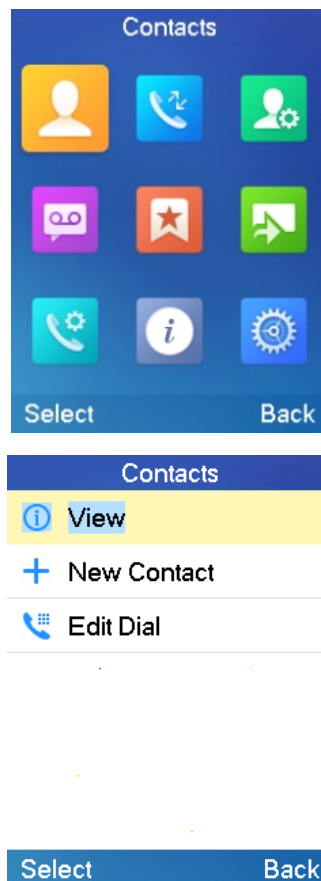

Figure 31: Create New Contact

Global Phonebook

Global phonebook allows to manage contacts and use them in all registered handsets. The contacts can be imported either via XML or via LDAP. Follow steps below to upload your shared phonebook:

Global Phonebook via XML

1. Access the Web GUI of your DP750 using the admin's username and password. (Starting HW version 1.7A the default admin username is 'admin' while the admin password is the random password that can be found on the sticker at the back of the unit. For lower hardware versions; the default username and password are: admin/admin).
2. Press Login to access your settings.
3. Go to **Phonebook** → **Global Phonebook XML Settings** tab.
4. Set **Global Phonebook Type** to **XML** (in this case, LDAP phonebook will not be available).

Global Phonebook XML Settings

Global Phonebook Type

Figure 32: Global Phonebook XML Settings

5. There are two methods to import/download your XML Phonebook:

o Automatic XML Phonebook Download

For this method, you need to use a TFTP or HTTP or HTTPS server and make your *phonebook.xml* file is available in your preferred server.

1. Set **Enable Automatic XML Phonebook Download** to **Enabled, use TFTP/HTTP or HTTPS** depending on your server.
2. If using HTTP or HTTPS server and User Name and Password are required to connect to the server, set **HTTP/HTTPS User Name** and **HTTP/HTTPS Password** fields with appropriate values.
3. Configure **Phonebook XML Server Path** field. This field could be IP address or URL, with up to 256 characters. The phone will request file named **phonebook.xml** from provided directory. Example: *192.168.5.1/Directory*
4. Configure the **Phonebook Download Interval** (in minutes) to periodically contact your server to download new phonebook file version if available. If set to 0, automatic download will be disabled. Valid range is 5 to 720.
5. Set **Remove Manually-edited Entries on Download** to **No** to keep any contact information entered from the handset directly while downloading your global phonebook file. If set to **Yes**, contacts manually entered from handset will be removed after downloading global phonebook.

Automatic XML Phonebook Download

Enable Automatic XML Phonebook Download	<input type="text" value="Enabled, use HTTP"/>
HTTP/HTTPS User Name	<input type="text"/>
HTTP/HTTPS Password	<input type="text"/>
Phonebook XML Server Path	<input type="text" value="192.168.5.1/Directory"/>
Phonebook Download Interval	<input type="text" value="60"/>
Remove Manually-edited Entries on Download	<input type="radio"/> No <input checked="" type="radio"/> Yes

Figure 33: Automatic XML Phonebook Download

o Manual XML Phonebook Management

1. Press **Upload** in **Import XML Phonebook**.
2. Browse your files and select your **phonebook.xml** file.

Manual XML Phonebook Management

Import XML Phonebook	<input type="button" value="Upload"/>	<input type="button" value="Delete"/>
Export XML Phonebook	<input type="button" value="Download"/>	
<input type="button" value="Save"/>		
<input type="button" value="Save and Apply"/>		
<input type="button" value="Reset"/>		

Figure 34: Manual XML Phonebook Management

XML Phonebook file format

```
<?xml version="1.0" encoding="UTF-8"?>
<AddressBook>
  <Contact>
    <FirstName>First name</FirstName>
    <LastName>Last name</LastName>
    <Ringtone>Ringtone ID (default 0)</Ringtone>
    <Phone type="Home">
      <phonenumber>Home phone number</phonenumber>
    </Phone>
    <Phone type="Work">
      <phonenumber>Work phone number</phonenumber>
    </Phone>
    <Phone type="Mobile">
      <phonenumber>Mobile phone number</phonenumber>
    </Phone>
  </Contact>
</AddressBook>
```

Object	Position	Type	Values	Comments
AddressBook	Root element	Mandatory	–	Root element of the XML document
Contact	Child element	Mandatory	–	Each contact is an entry
LastName	Child element	At least one of them present	String	Last name of the contact
FirstName	Child element	String	First name of the contact	
Phone	Child element	Mandatory	–	Phone number
PhoneNumber	Child element	At least one present	Int	Type="Home" or Type="Work" or Type="Mobile"

XML Phonebook Example:

```

<?xml version="1.0" encoding="UTF-8"?>
<AddressBook>
  <Contact>
<?xml version="1.0" encoding="UTF-8"?>
<AddressBook>
  <Contact>
    <FirstName>John</FirstName>
    <LastName>Doe</LastName>
    <Ringtone>0</Ringtone>
    <Phone type="Home">
      <phonenumber>1000</phonenumber>
    </Phone>
    <Phone type="Work">
      <phonenumber>1001</phonenumber>
    </Phone>
    <Phone type="Mobile">
      <phonenumber>1002</phonenumber>
    </Phone>
  </Contact>
<Contact>
  <FirstName>Alice</FirstName>
  <LastName>Beck</LastName>
  <Ringtone>0</Ringtone>
  <Phone type="Home">
    <phonenumber>2000</phonenumber>
  </Phone>
  <Phone type="Work">
    <phonenumber>2001</phonenumber>
  </Phone>
  <Phone type="Mobile">
    <phonenumber>2002</phonenumber>
  </Phone>
</Contact>
</AddressBook>

```

Global Phonebook via LDAP

1. Access the Web GUI of your DP750 using the admin's username and password.
2. Press **Login** to access your settings.
3. Go to **Phonebook** → **Global Phonebook LDAP Settings** tab.
4. Set **Global Phonebook Type** to **LDAP** (in this case, XML phonebook will not be available).

Global Phonebook LDAP Settings

Global Phonebook Type

Figure 35: Global Phonebook LDAP Settings

5. Under **LDAP Phonebook Settings**, set your LDAP parameters to connect to your LDAP server. Refer to [Table 11: Phonebook Page Definitions](#) for parameters explanation.
6. Press **Save and Apply** to save your configuration.
 - o **Example of configuration:**

```

LDAP protocol: LDAP
Server Address: 192.168.1.100
Port: 389
Base: dc=pbx,dc=com
User Name:
Password:
LDAP Number Filter: (AccountNumber=%)
LDAP Name Filter: (CallerIDName=%)
LDAP Version: Version 3
LDAP Name Attributes: CallerIDName Email Department FirstName LastName
LDAP Number Attributes: AccountNumber MobileNumber HomeNumber Fax
LDAP Display Name: AccountNumber CallerIDName
Max. Hits: 50
Search Timeout: 30
Sort Results: Yes
LDAP Lookup: Incoming Calls / Outgoing Calls (checked)
Lookup Display Name: FirstName LastName

```

After applying your configuration, your global phonebook will be synchronized with all registered handsets and contacts will be displayed on your DP720 handsets screens.

DP750 ASSOCIATION WITH DP760 DECT REPEATER

Notes

- DP760 can relay up to 2 concurrent calls.
- After pressing Page/Reset button for more than 2 seconds on the DP760, it will enter AUTO region mode, in this mode, the three LEDs of right side keep quick blinking, then the DP760 will search the base signal in the current environment to auto associate with it and then auto switch to the same region (EU, US or BR) of the base station.
- If you have a DP760 that has FW before 1.0.3.34, you will need upgrade it to 1.0.3.34 first, then do a factory reset. After that, the unit will support Auto-Region feature and it will enter Auto Region mode.

Enabling Repeater Mode on DP750

Before associating the DP760 DECT Repeater to your DP750 Base Station, you should firstly enable the repeater mode on your base station. Please refer following steps to enable the repeater mode on the DP750 base station:

1. Access the Web GUI of your DP750 using the admin's username and password.
2. Navigate to **DECT → General Settings** and set **Enable Repeater Mode** to **Yes**.

The screenshot shows the 'DECT' section of the Web GUI with 'General Settings' selected. The settings are as follows:

Setting	Value
Base Station Name	DP750_870884
Admin PIN Code	
Enable Repeater Mode	<input type="radio"/> No <input checked="" type="radio"/> Yes
Enable Repeater Management	<input type="radio"/> No <input checked="" type="radio"/> Yes
Clear Call Logs	<input type="button" value="Delete"/>

Figure 36: Enable Repeater Mode

3. Press **Save and Apply**, then **Reboot** the base to apply the new settings.



DP760 DECT Repeater Association

After enabling the repeater mode on DP750 Base Station, you can easily associate it with your DP760 DECT Repeater using one of the following methods:

- **Auto Association**
- **Manual Association**
- **Use DP750 Repeater Management to associate DP760**

Auto Association

To auto associate your DP760 DECT Repeater with DP750 Base Station:

1. Power on the DP760 DECT Repeater.
2. After the DP760 finish booting, the association LED  will be blinking to indicate that the repeater is searching for nearby base stations.
Note: If all the LEDs remain on, it indicates that the DP760 Repeater has successfully associated with a DP750 Base and ready for use. You may need to dissociate it before continuing (Please refer to [DP760 DECT REPEATER DISSOCIATION FROM DP750]).
3. Open subscription on your DP750 Base Station using one of following methods:
 - Rebooting the Base station.
 - Long press on page/subscribe button on the back panel of DP750 for 7 seconds.
 - Access DP750 Web GUI and press subscribe button .
4. The DP760 DECT Repeater will automatically pair to DP750. Upon successful association with the DP750 Base station all LEDs will turn ON and the repeater status will be updated as following.



Status	DECT Repeater Status	
DECT Repeater Status		
Network Status		
System Info		
DECT Repeater Status		
Repeater Name	DP760_9e274c	
Repeater FW Version	FW 03.00 Build 1294	
Repeater DECT RF Region	EU	
Repeater Status		
Status	Repeater is in normal operation	
Signal Strength	Link is excellent	
Number of Active Calls	0	
Global Functions		
Base Station RFPI Address	02C344DDA0 (RPN 2)	
Base Station IP Address	192.168.5.141	
Disconnect from Base Station	Disconnect	

Figure 37: Repeater Status – Associated (Auto Association)

Notes

- For auto association, the option **Use manually configured RFPI** under DP760 Web GUI should be disabled (by default disabled).
- The RF auto association requires the repeater to be close to the base during the pairing process to work properly (this is a standard DECT repeater pairing limitation).

Manual Association

To manually associate your DP760 DECT Repeater to your DP750 Base Station:

1. Access the Web GUI of your DP760 using the admin's username and password.
2. Navigate to **DECT → General Settings** and set **Use Manually Configured RFPI** to **Yes**.
3. On **Manually Configured Base RFPI** field, configure your DP750 Base Station RFPI address.
Note: The RFPI Address of your DP750 Base Station is available under the Web GUI → **Status → DECT Status → Base DECT RFPI Address**.
4. Click **Save and Apply** to confirm the new settings.
5. Open subscription on your DP750 Base Station using one of following methods:
 - Rebooting the Base station
 - Long press on page/subscribe button on the back panel of DP750 for 7 seconds
 - Access DP750 Web GUI and press subscribe button .
6. The DP760 DECT Repeater will automatically pair to DP750. If the association is correctly associated, all the LEDs will remain solid on and the repeater status will be updated as following

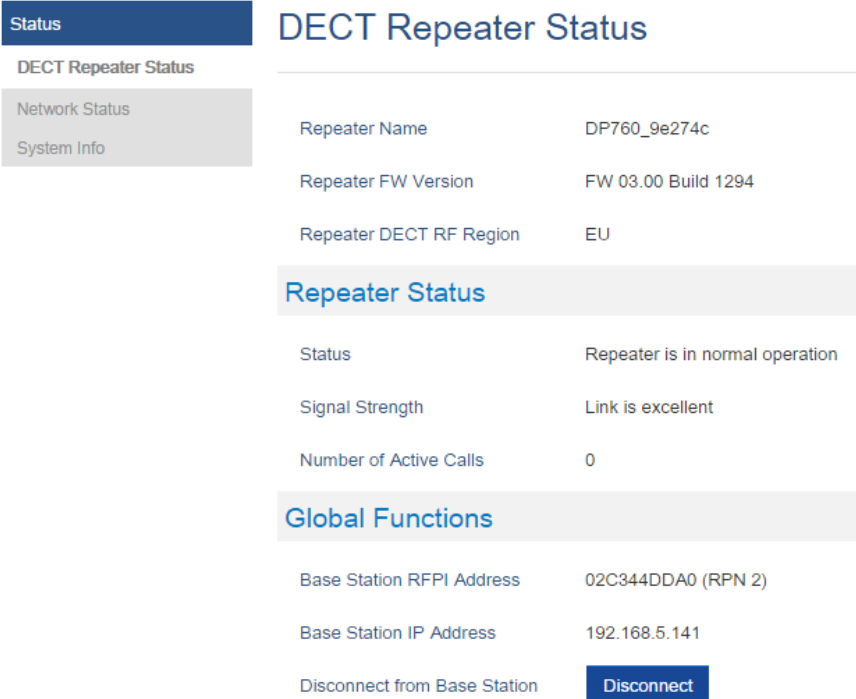

Status	DECT Repeater Status	
Network Status		
System Info		
Repeater Name	DP760_9e274c	
Repeater FW Version	FW 03.00 Build 1294	
Repeater DECT RF Region	EU	
Repeater Status		
Status	Repeater is in normal operation	
Signal Strength	Link is excellent	
Number of Active Calls	0	
Global Functions		
Base Station RFPI Address	02C344DDA0 (RPN 2)	
Base Station IP Address	192.168.5.141	
Disconnect from Base Station	Disconnect	

Figure 38: Repeater Status – Associated (Manual Association)

Note

Make sure that **Repeater Mode** is enabled on your DP750 Base Station.

Use DP750 Repeater Management to Associate DP760

- **Enabling Repeater Management Mode**

The following steps illustrate how to enable and use the Repeater Management mode on DP750:

1. Access the Web GUI of your DP750 using the admin's username and password.
2. Navigate to **DECT → General Settings** and set **Enable Repeater Management** to **Yes**.
3. Press **Save and Apply**, then reboot the unit to apply the new settings.

Figure 39: Repeater Associated Status

o **Associating DP760 using Repeater Management Mode on DP750**

The repeater management mode displays discovered and paired devices using their name, IP and Mac addresses and also gives the possibility of associating the DP750 Base Station with DP760 DECT Repeater.

Please refer to following steps in order to associate DP760 with DP750 using repeater management mode:

1. Access the Web GUI of your DP750 using the admin’s username and password.
2. Navigate to **Status → DECT Repeater Status** and select the repeater station from **Discovered Devices**.
3. Click **Link** button to associate the base and repeater stations.

Notes

The DP760 Repeater stations associated with DP750 Base Station are displayed and available under **Status → DECT Repeater Status → Paired Devices** with their status, signal strength, number of active calls and possibility to disconnect them from the paired base station.

Figure 40: DECT Repeater Status on DP750

DP760 DECT REPEATER DISSOCIATION FROM DP750

To disconnect DP760 DECT Repeater from the Base Station DP750, please refer to following options:

Using DP760 Web GUI

To disconnect your DP760 DECT Repeater via Web GUI, please refer to following steps:

1. Access the Web GUI of your DP760 using the admin's username and password (Starting HW version 1.3A the default admin username is 'admin' while the admin password is the random password that can be found on the sticker at the back of the unit. For lower hardware versions; the default username and password are: admin/admin)
2. Enter the administrator's username and password to access the Web Configuration Menu.
3. Navigate to **Status** → **DECT Status** → **Global Functions** and press **Disconnect**.
4. The DP760 DECT Repeater will be automatically disconnected from the DP750 and it will start again scanning for available RFPs.

Status

DECT Repeater Status

Network Status

System Info

DECT Repeater Status

Repeater Name: DP760_8b556b

Repeater FW Version: FW 03.00 Build 1294

Repeater DECT RF Region: EU

Repeater Status

Status: Repeater is in normal operation

Signal Strength: RF Link is excellent

Number of Active Calls: 0

Global Functions

Base Station RFPI Address: 02C344DDA0 (RPN 3)

Disconnect from Base Station: **Disconnect**

Figure 41: DECT Repeater Status on DP750

Using Page Button

Long press on page button on the back panel of DP760 for 7 seconds, it will remove the association values of the previous base station.

Using Repeater Management Mode on DP750

To disconnect your DP760 DECT Repeater using the repeater management mode on DP750:

1. Access the Web GUI of your DP750 using the admin's username and password.
2. Navigate to **Status** → **DECT Repeater Status**.
3. Select the repeater station from **Discovered Devices**.
4. Click **Unlink** button to dissociate the repeater from the base station.

Status

Account Status

DECT Base Status

DECT Repeater Status

Line Options

Network Status

System Info

DECT Repeater Status

Paired Devices

Model	Name	IP	MAC	Status	Signal Strength	Active Calls	Unlink
DP760	DP760_8b556b	192.168.5.125	000b828b556b	online	RF Link is excellent	0	Unlink

Figure 42: DECT Repeater Status on DP750

UPGRADING AND PROVISIONING

The DP750 can be upgraded via FTP/FTPS/HTTP/HTTPS by configuring the URL/IP Address for the FTP/FTPS/HTTP/HTTPS server and selecting a download method. The server name can be FQDN or IP address.

Examples of valid URLs:

firmware.grandstream.com

fw.ipvideotalk.com/gs

DP750 Firmware Upgrade Procedure

Please follow below steps in order to upgrade the firmware version of your DP750 base station:

1. Access DP750 Web GUI.
2. Press **Login** to access your settings.
3. Go to **Maintenance** → **Firmware Upgrade** page, enter the IP address or the FQDN for the upgrade server in "**Firmware Server Path**" field and choose to upgrade via FTP/FTPS or HTTP/HTTPS.
4. Make sure to configure Firmware **Upgrade and Provisioning** to **Always Check for New Firmware**.
5. Update the change by clicking the "**Save and Apply**" button. Then "**Reboot**" or power cycle the base station to update the new firmware.

Maintenance | **Firmware Upgrade**

Firmware Upgrade

Provisioning
Web/SSH Access
TR-069
Security Settings
Date and Time
Syslog
Packet Capture
Factory Reset
Support

Base Firmware

Firmware Upgrade Always Check for New Firmware
 Check New Firmware Only When F/W pre/suffix Changes
 Always Skip the Firmware Check

HTTP/HTTPS/FTP/FTPS User Name

HTTP/HTTPS/FTP/FTPS Password

Always send HTTP Basic Authentication Information No Yes

Verify host when using SSL No Yes

Upgrade via HTTP HTTPS FTP FTPS

Firmware Server Path

Firmware File Prefix

Firmware File Postfix

Allow DHCP Options 43, 66 and 160 to override Server No Yes

Automatic Upgrade No
 Yes, check for upgrade at random every day(s)
 Yes, check for upgrade every minute(s)
 Yes, check for upgrade every day
 Yes, check for upgrade every week

Random Interval Start Time :

Random Interval Stop Time :

Hour of the Day(0-23)

Day of the Week (0-6)

Firmware Key

Upgrade

Handset Firmware

Handset firmware

Automatic Upgrade No Yes

Upgrading via Local FTP/HTTP Servers

For users that would like to use remote upgrading without a local FTP/HTTP server, Grandstream offers a NAT-friendly HTTP server. This enables users to download the latest software upgrades for their devices via this server. Please refer to the webpage: <http://www.grandstream.com/support/firmware>

Alternatively, users can download a free FTP or HTTP server and conduct a local firmware upgrade. A free windows version FTP server is available for download from:

<https://filezilla-project.org/download.php?type=server>

Instructions for local firmware upgrade via FTP:



1. Unzip the firmware files and put all of them in the root directory of the FTP server.
2. Connect the PC running the FTP server and the phone to the same LAN segment.
3. Start the FTP server and configure the FTP server in the phone's web configuration interface.
4. Configure the Firmware Server Path to the IP address of the PC.
5. Configure the Admin and password authentication Credentials set on your FTP server.
6. Save and apply the changes and reboot the base station.

End users can also choose to download a free HTTP server from <http://httpd.apache.org/> or use Microsoft IIS web server.

Upgrading DP720 handset

User could upgrade their handsets either using the LCD menu or via the Web GUI

Using the LCD menu

1.   On DP720, press "Menu" (left softkey or the selection key) to bring up operation menu.
2. Press arrow keys to move the cursor to **Settings** and then press "Select".
3. Navigate to **Firmware Upgrade** and press "Select" (left softkey), the handset will upgrade the firmware available on the base station.

Using the Web GUI

1. Access DP750 Web GUI.
2. Press **Login** to access your settings.
3. Go to **Maintenance** → **Firmware Upgrade** page, and enable the **Automatic Upgrade** option so the handset will upgrade the firmware automatically once it detects the new firmware.



Figure 44: Handset Firmware Upgrade

4. Update the change by clicking the "**Save and Apply**" button.

Notes

- The DP720 handset detects automatically if the base station is upgraded with a new firmware and display on the LCD a prompt message inviting the user to initiate the upgrade, more over under the Web GUI of the base station DP750 → Status → DECT Status → Handset Status, appears an **Upgrade All** button once the base detect that several registered handsets are using an old firmware version so the user could upgrade all handsets by pressing **Upgrade All** button.
- After downloading firmware, DP720 screen will be black and red LED will be blinking showing that firmware upgrade process is ongoing.

DP750/DP720 Provisioning

Configuration File Download

Grandstream SIP Devices can be configured via the Web Interface as well as via a Configuration File (binary or XML) through TFTP, FTP/FTPS, or HTTP/HTTPS. The **Config Server Path** is the TFTP or HTTP/HTTPS server path for the configuration file. It needs to be set to a valid URL, either in FQDN or IP address format. The **Config Server Path** can be the same or different from the **Firmware Server Path**.

A configuration parameter is associated with each particular field in the web configuration page. A parameter consists of a Capital letter P and 2 to 3 (Could be extended to 4 in the future) digit numeric numbers. i.e., P2 is associated with the "New Password" in the Web GUI → Maintenance → Web/SSH Access page → Admin Password.

The downloaded config file now will display the P value in new format, that has more meaningful name of the parameter being configured. Below is an example of how new P values looks like, please note that the old numeric P values will still be working, for example, in a single config file, the user can choose to use P values in the format of P9 or Pnetworks.static.address.ip.octet.1, or mixed format for different settings, the device will takes all of them. We are still improving the downloaded config file by adding the help text and re-ordering the settings to match the web.

```

7 <!--## Configuration Template ##-->
8 <!--#####-->
9 <!--#####-->
10 <!--## P values ##-->
11 <!--#####-->
12 <!--# Name: 8-->
13 <!--# Alias: network.type,NETWORK_TYPE # Help: IP Address Mode. 0 - DHCP, 1 - Static IP, 2 - PPPoE.-->
14 <!--# Attributes: Category=NUMBER Mandatory=1 Base=10 Range=[0-2] -->
15 <!--# Default Value: 0-->
16 <Pnetwork.type>0</Pnetwork.type>
17
18
19 <!--# Name: 9-->
20 <!--# Alias: network.static.address.ip.octet.1,NETWORK_STATIC_ADDRESS_OCTET1 # Help: IP Address octet 1. Ignore if DHCP or PPPoE is
used.-->
21 <!--# Attributes: Category=NUMBER Mandatory=1 Base=10 Range=[0-255] -->
22 <!--# Default Value: 192-->
23 <Pnetwork.static.address.ip.octet.1>50</Pnetwork.static.address.ip.octet.1>
24
25
26 <!--# Name: 10-->
27 <!--# Alias: network.static.address.ip.octet.2,NETWORK_STATIC_ADDRESS_OCTET2 # Help: IP Address octet 2. Ignore if DHCP or PPPoE is
used.-->
28 <!--# Attributes: Category=NUMBER Mandatory=1 Base=10 Range=[0-255] -->
29 <!--# Default Value: 168-->
30 <Pnetwork.static.address.ip.octet.2>84</Pnetwork.static.address.ip.octet.2>
31
32
33 <!--# Name: 11-->
34 <!--# Alias: network.static.address.ip.octet.3,NETWORK_STATIC_ADDRESS_OCTET3 # Help: IP Address octet 3. Ignore if DHCP or PPPoE is
used.-->
35 <!--# Attributes: Category=NUMBER Mandatory=1 Base=10 Range=[0-255] -->
36 <!--# Default Value: 0-->
37 <Pnetwork.static.address.ip.octet.3>167</Pnetwork.static.address.ip.octet.3>
38
39

```

Note

For a detailed parameter list, please refer to the corresponding firmware release configuration template.

When the DP750 boots up or reboots, it will send a request to download a file named "cfgxxxxxxxx" followed by a configuration XML file named "cfgxxxxxxxx.xml", where "xxxxxxxx" is the MAC address of the phone, i.e., "cfg000b820102ab" and "cfg000b820102ab.xml". If the download of "cfgxxxxxxxx.xml" file is not successful, the DP750 will send a request to download a file named "cfgdp750.xml" to allow provisioning by a model specified xml file. If the download is still unsuccessful then the provision program will download a generic cfg.xml file. The configuration file name should be in lower case letters.

For more details on XML provisioning, please refer to:

<https://documentation.grandstream.com/knowledge-base/sip-device-provisioning-guide/>

Handset Provisioning

To configure the handset provisioning, please browse the base station Web GUI at Maintenance → Provisioning. This is the same page used for base station provisioning. Handset shares the settings of base station provisioning in the field in the red rectangle, and has its own settings in the blue rectangle. After enabled Handset Config Upgrade, need reboot the DP750 to take effect.

Maintenance

Firmware Upgrade

Provisioning

Web/SSH Access

TR-069

Security Settings

Date and Time

Syslog

Packet Capture

Factory Reset

Support

Provisioning

XML Config File Password

HTTP/HTTPS/FTP/FTPS User Name

HTTP/HTTPS/FTP/FTPS Password

Always send HTTP Basic Authentication Information No Yes

Verify host when using SSL No Yes

Provisioning via TFTP HTTP HTTPS FTP FTPS

Config Server Path

Config File Prefix

Config File Postfix

Enable Handset Config Upgrade No Yes

Handset Config File Prefix

Handset Config File Postfix

Allow DHCP Options 43, 66 and 160 to Override Server No Yes

Figure 45: Provisioning Feature

- **Provisioning via:** Choose the method that the base station uses to request handset ipei config file. Can use TFTP, HTTP, FTPS, FTP or HTTPS.
- **Config Server Path:** Defines the server path for provisioning. Do not prepend address with "http://" or any other protocol.
- **Handset Config File Prefix:** If configured, only the handset configuration file with the matching encrypted prefix will be downloaded and flashed into the device.
- **Handset Config File Postfix:** If configured, only the handset configuration file with the matching encrypted postfix will be downloaded and flashed into the device

When a DP720 registers to a DP750 for the first time or an already registered handset boots up, the DP750 will send a provisioning request for a file on the configured provisioning server, with location "Config_Server_Path/[Prefix][HS IPEI].xml[Postfix]". For example, if handset's IPEI number is 02c332b510, prefix is "ipei_", postfix is null, and config server path is "fw.grandstream.com/gs", the request URL is "fw.grandstream.com/gs/ipei_02c332b510.xml".

For more detailed information, please refer to [Handset Provisioning Guide](#).

RESTORE FACTORY DEFAULT SETTINGS

Note

Restoring the Factory Default Settings will delete all configuration information on the phone. Please backup or print all the settings before you restore to the factory default settings. Grandstream is not responsible for restoring lost parameters and cannot connect your device to your VoIP service provider.

Resetting the DP750 Base Station

There are two methods to reset your base station to the default setting:

Via Reset Button

1. Locate the reset hole on the back panel of your DP750.
2. Insert a pin in this hole, and press for about 7 seconds.
3. Take out the pin. The unit will restart automatically with parameters restored to default values.



Note: A quick press on the reset hole will just reboot the unit.

Via Web GUI

1. Access DP750 Web GUI.
2. Navigate to **Maintenance** → **Factory Reset**.
3. Select the **Reset Type** from the reset drop down list.
4. Press **Reset** button and the unit will prompt a confirmation message, press **OK** to reset, then the unit restart automatically with parameters restored to default values or press **Cancel** to annul the reset.

Resetting the DP720 Handset

Please follow the instructions below to reset the DP720 Handset:

1.   Press "Menu" (left softkey or the selection key) to bring up operation menu.
2. Press arrow keys to move the cursor to **Settings** and then press "Select".
3. Navigate to **System Settings** → **Factory Reset**, a warning window will pop out to make sure a reset is requested and confirmed;
4. Press "**Yes**" (left softkey) to confirm and the phone will reboot.

To cancel the Reset, press "**No**" (right softkey) instead.

Users also can perform factory reset using combo keys on DP720 during booting up prior it's fully booted, to give DP720 the ability to recover from some extreme cases like self-reboot or stuck right after booted up.

Please refer to following procedure for DP720 factory reset using combo key:

1. Connect the USB cable and power off DP720.
2. Power on DP720 and wait for Green LED.
3. Press 3 times Central Key (OK/Selection Key) quickly after Green LED on.
4. Press Speaker Key (left bottom) first and then Mute Key (right bottom) after Red LED on.
5. DP720 LED will start blinking in 3 colors: Green, Red and Orange if factory reset successful triggered.
6. Wait for about 1-3 minutes, the DP720 will boot up with setup wizard for initial language and date format settings.

CHANGE LOG

This section documents significant changes from previous firmware versions. Only major new features or major document updates are listed here. Minor updates for corrections or editing are not documented here.

Firmware Version 1.0.19.6

- Add SRTP mode "Optional" under SRTP options. [[SRTP Mode](#)]
- Added "Kandy" Special Feature mode for ITSP. [[Special Feature](#)]

Firmware Version 1.0.19.5

- Added support for "Allow SIP Reset". [[ALLOW SIP RESET](#)]

Firmware Version 1.0.19.4

- Added ability to handle all SRV responses when using NAPTR/SRV as DNS mode for Telstra ITSP. [[Special Feature](#)]

Firmware Version 1.0.19.3

- Added support for SSL Key Log File. [[WITH SECRET KEY INFORMATION](#)]
- Added support for Alert-info in string format. [[Alert Info](#)]

Firmware Version 1.0.19.2

- Added support for XMPP connection on TR-069. [[XMPP](#)]
- Added option to use # as Redial key. [[Redial key](#)]
- Added preferred primary outbound proxy feature. [[Outbound Proxy](#)]
- Integrated new DigiCert certificates in firmware. [[DigiCert certificates](#)]
- Added new option "Follow SIP Transport to SRTP mode" to auto-switch between RTP and SRTP according to the resolved SIP transport. [[Follow SIP Transport](#)]
- Added the ability to configure F-timer and B-timer. [[F-Timer](#)] [[B-Timer](#)]
- Added support DP75x for new Cisco/BW Failover/Failback Requests. [[Maximum Number of SIP Request Retries](#)] [[Failback Expiration](#)]
- Updated the default value of "Unregister on Reboot" to "No". [[Unregister on Reboot](#)]
- Added support for the Greek language.

Firmware Version 1.0.17.8

- No major changes.

Firmware Version 1.0.17.4

- No major changes.

Firmware Version 1.0.17.3

- Added support for Off-Hook Auto-Dial Delay. [[Table 11: DECT page settings](#)]

Firmware Version 1.0.17.1

- Add support to automatically reboot. [[Automatic Reboot](#)]

Firmware Version 1.0.15.15

- Add support to allow call barging by Call-Info/Alert-Info. [[Allow Barging for Auto Answer by Call-Info/Alert-Info](#)]
- Added HW version display on device web GUI status page. [[Hardware Version](#)]
- Adjust Opus to be configured with default value 123 as the same as GRP. [[OPUS Payload Type](#)]

Firmware Version 1.0.15.6

- No major changes.

Firmware Version 1.0.15.3

- Added support to have a web UI option of bypass dial plan. [[Bypass Dial plan](#)]

Firmware Version 1.0.15.2

- Add support to input provisioning server username and password on handset UI when base station is trying to download a config file from a password protected server. [[User Name](#)] [[Password](#)].
- Added support to configure Call Log settings. [[Call Log](#)]
- Added DNS SRV Failover modes. [[DNS SRV Failover mode](#)]

- Added warning tone when auto answer a call or intercom. [Play warning tone for Auto Answer Intercom]
- Added option to automatically mute after auto answer a call or intercom. [Enable Mute for Auto Answer]
- Added support to disable SIP NOTIFY authentication. [Disable SIP NOTIFY Authentication]
- Added support for Auto Timer Zone feature. [Time Zone]
- Added support to delete a paired base station from the handset.

Firmware Version 1.0.13.8

- Added support to enable or disable “On Hold Reminder Tone” in Web UI. [On Hold Reminder Tone]
- Added support for paging between handsets without account registered. [Call Features]
- Added ability to configure Caller ID Display. [Caller ID Display]
- Updated the CPE to 1.0.1.141 to better support GDMS.

Firmware Version 1.0.13.0

- No major changes.

Firmware Version 1.0.11.12

- Added support for SNMP. [SNMP Settings]
- Added support for management interface settings that uses a virtual network interface. [Management Interface Settings]
- Added support for Broadsoft XSI phonebook. [Broadsoft XSI]
- Added support for Feature Key Synchronization that support both Broadsoft and MetaSwitch, or any server that following the same feature key synchronize standard. [Feature Key Synchronization]
- Added support for option “Backup Outbound Proxy” in all Profiles. [Backup Outbound Proxy]
- Added support for option “Use SBC” in all Profiles. [Use SBC]
- Added option to use sip or sips for SIP URI scheme when using TLS. [SIP URI Scheme When Using TLS]
- Added option to use actual ephemeral port in contact with TCP/TLS. [Use Actual Ephemeral Port in Contact with TCP/TLS]
- Added OpenVPN® Comp-Izo option under OpenVPN® Settings page. [OpenVPN® Comp-Izo]
- Added option to disable web access. [Web Access Mode]

Firmware Version 1.0.11.4

- No major change.

Firmware Version 1.0.11.2

- Added DP75X Callee Codec Negotiation Priority option. [Callee Codec Negotiation Priority]
- Added Chile time zone. [Time Zone]
- Added support to bypass the dial plan check when redial / call back phone number via call history.[Dial Plan bypass]
- Changed SIP account name length from 14 characters to 256. [Name]

Firmware Version 1.0.9.9

- Added DP75X Trusted CA Certificate option for HTTPS/FTPS. [Security]
- Added support to configure customized time zone and daylight-saving time (DST) on the web UI. [Custom Time Zone Settings]
- Increased DP75X web UI voice mail user ID character length to 30. [Voice Mail Access Number]
- Increased SIP Certificate length limitation from 2048 characters to 8192. [SIP TLS Certificate]
- Added support to configure Voice Mail access number on DP75X web UI. [Voice Mail Access Number]
- Added support for FTP/FTPS User Name/Password for firmware upgrade and provisioning. [UPGRADING AND PROVISIONING]

Firmware Version 1.0.9.1

- Added option to enable or disable Session Timer for DP75x. [Enable Session Timer]
- Added support of EXTRA DEBUG level Syslog for DP75X. [Syslog Level]
- Add ability to manually configure date and time on the base Web GUI. [Manual Time Settings]
- Added support to enable or disable "Allow Unsolicited REFER" option for DP750. [Allow Unsolicited REFER]
- Change DP720 Preferences option "Mute as DND" default to "Enabled" from "Disabled" to make enabling DND more convenient. [Mute as DND]
- Added support for Intercom feature. [Shortcut]

Firmware Version 1.0.7.5

- Changed DP720 GUI to new design with new style.
- Added support for Push-to-Talk for DP720.[Shortcut] [DECT PTT Silence Timer][PTT]
- Added support to work with GDS3710/GDS3705 to remote open door with "Open" button. [External Service]
- Added support for "Music on Hold URI" for DP750. [Music On Hold URI]
- Disable DP720 auto upgrade to 1.0.7.X or above.
- Added support for new format of P values.[DP750/DP720 Provisioning]

Firmware Version 1.0.4.10

- Added option to add MAC address to User Agent. [Use MAC Header]

Firmware Version 1.0.4.7

- Added the ability to display Account Name only. [SIP Account Display]
- Added support to provision config file by model. [DP750/DP720 Provisioning]
- Added support TLS protocol for Syslog. [Syslog Protocol]
- Added SRTP icon on handset UI. [Table 8: DP720 Icons Description]
- Updated German translations for both DP750 Web UI and DP720 handset UI.

Firmware Version 1.0.4.2

- Added support for CTI (Computer-Telephony Integration) feature. [CTI Guide]
- Improve the support to customize the Syslog port. [Syslog port]
 - Added support for DP720 to use Audio Loopback test when it is not registered to the base station. [Audio Loopback]
 - Play keypad tone during the call if it is enabled. [Audio]

Firmware Version 1.0.3.40

- Added support to allow configure prefix for User-Agent in SIP header. [User-Agent Prefix]
- Increased the length of Authenticate ID, SIP User ID, Password from 32 to 128.
- Added support for SIP OPTIONS Keep Alive. [Enable OPTIONS Keep Alive]
 - Added support for automatic upgrade and provisioning be triggered at a random time in every certain day. [Automatic Upgrade]
- Added OpenVPN feature. [OpenVPN]
 - Added the option to set Date and Time Display Format via the web GUI and Provisioning. [Time Format]

Firmware Version 1.0.3.37

- Added support for DP750 to configure device with custom certificate signed by custom CA certificate. [Device Custom Certificate]

- Added support for DP750 to customize the Syslog port. [Syslog port]
- Reset DP760 repeater region to AUTO when pressing page and reset button more than 2s. [DP750 ASSOCIATION WITH DP760 DECT REPEATER]

Firmware Version 1.0.3.34

- No major changes.

Firmware Version 1.0.3.31

- Added language support for Slovakian, Swedish. [Web GUI Languages]
- Change NTP Server default value to pool.ntp.org. [NTP Server]

Firmware Version 1.0.3.23

- Added Email address to core debug page. [Email Address]
- Implemented Handset Provisioning feature. Add warning information to SIP Account Settings and Line Settings Pages if Handset Provisioning enabled. [Handset Provisioning]
- Added support for more languages and updated translation. [Multi-language]
- Implemented DP750 Debug Tools that allow generate and submit debug files to Grandstream debug server directly. [Debug Tools]
- Add handset notification for base core dump files. [Handset Notification]
- Added web UI support to DP750 for repeater management such as display/link/unlink, etc. [DECT Repeater Status]
- Added backup configuration feature. [Backup Configuration]
- Added UPnP discovery feature. [UPnP Discovery Settings]
- Added support for more languages and updated translation. [Web GUI Languages]
- Added DP750/DP720 product resource link to DP750 web UI. [Support Documentation]
- Added support for page refresh by Refresh Page button, and added the icons of Refresh Page, Open Subscription and Page All button to icon bar. [Icons Bar Shortcut]
- Added support to auto-refresh on DECT status web UI. [DECT Base Status]
- Added the ability to customize DP720 ringtones. [Custom Ringtone]
- Enhanced factory reset feature by adding options to select Full RESET, RESET without deleting handsets subscription or RESET only deleting handset subscription. [Reset Type]
- Added capability to rename the profile. [Profile Name]
- Added support for Distinctive Ringtone based on a customized SIP Alert-info header. [Match Incoming Caller ID]
- Removed "Disable Call Waiting Tone" from Profile page and add it under DECT → Handset Settings [Disable Call Waiting Tone]
- Added support to upload TXT configuration file. [Upload Device Config]
- Added a new tab named "Support" under Maintenance page for support document, configuration support and debug tools. [Support]
- Added DP750 the ability to send SIP INFO and RFC2833 at same time. [Send DTMF]
- Added force reboot button to web UI to force reboot DP750 in factory reset page under maintenance section. [Force Reboot]

Firmware Version 1.0.2.16

- Added TR-069 CPE support. [TR-069]
- Added Repeater mode support at DECT → General Settings. [Enable Repeater Mode]
- Added support of plus button '+' when dialing. [Dial Plan]
- Added "Verify host when using HTTPS" option at Maintenance → Firmware Upgrade. [Verify host when using HTTPS]
- Added status displays as "Normal" when core dump list is empty.
- Added "Access Control Lists" at Maintenance → Web/SSH Access. [Access Control Lists]

- Added support for HTTPS web access. [HTTPS Web Port][HTTP / HTTPS Web Port]
- Changed menu "Line Status" in Call Settings to "Lines".
- Improved DNS Settings page. [Network Settings – Basic Settings]
- Re-arranged the Setting Status menu. [DP720 Handset Menu]
- Add documents and drilling templates to web GUI support page. [Support]
- Web UI Enhancements
- Improved support for Czech, Dutch, German, Hebrew, Japanese, Korean, Turkish languages.

Firmware Version 1.0.1.14

- Removed IVR (Interactive Voice Response).
- Hide the content of "Advanced Settings" page when accessing the web GUI with normal user. [Web UI Access Level Management]
- Added voice mail, missed calls, headset icons. [Table 8: DP720 Icons Description]
- Moved Download Config options to Provisioning page. [Provisioning]
- Added Dialing box controls for off-hook dialing on DECT → General Settings. [General Settings]
- Changed EU standard ring tog tone same as US. [Ring Tones]
- Added support for configurable system ring tone on Settings → Ring Tones. [Ring Tones]
- Added web UI support for packet capture on Maintenance → Packet Capture [Packet Capture].
- Removed "Internal call" from audio ring tone menu.
- Removed "Intercom" feature completely.

Firmware Version 1.0.1.4

- Added dialing box controls for off-hook dialing on Profile → Call Settings.
- Added Reset handset name to default if handset is unsubscribed.
- Added DHCPv4 Option 120 on Maintenance → Provisioning. [Provisioning]
- Move Network Settings and Phonebook tabs. [Network Settings] [Phonebook Page Definitions]
- Added handset version (firmware) on Status → System Status.
- Web UI Status Enhancements.
- Changed location of handset firmware upload/delete.
- Improved web UI Account Status page.
- Added processing of DHCP option 160 by DHCP client.
- Added support to receive a handset proprietary message when handset power off.
- Added "Off-Hook Auto-Dial " option on DECT → General Settings. [Off-hook Auto-dial]
- Added support to upload handset firmware from web UI. [Handset Firmware]
- Added delete button for uploaded handset firmware via web UI. [Handset Firmware]

Firmware Version 1.0.0.16

- This is the initial version for DP750/DP720.

Need Support?

Can't find the answer you're looking for? Don't worry we're here to help!

CONTACT SUPPORT